



Product Documentation

Series 200-6XC

Installation and Operating Guide

Instruction Set for Continental™ Styled
6 Cylinder EXPERIMENTAL Engines



V 200-6XC .043
Continental Style

Changes to Manual: Changes, corrections, and supplements may be made at any time (see version number on cover page – bottom right). Refer to E-MAG's web page "Downloads" for the most recent version.

Alerts and Service Notes: Prior to installation and operation, review all applicable Alerts and Service Notes affecting your equipment. See E-MAG web site <https://emagair.com/service-notes/>.

Experimental Aircraft Only: Series 200-6X ignitions are not certified and are not approved for installation on certificated aircraft.

Warranty: E-MAG electronic ignitions are warranted for one (1) year from the date of purchase. E-MAG will repair or replace ignition modules within the warranty period that, in E-MAG's sole opinion, have not been subjected to abuse or attempted field repairs. This warranty is limited to the purchase price of E-MAG hardware and does not cover the engine or other engine components that may be affected by defects or failure of the system. Do not attempt to open or separate the ignition case sections. Doing so will void your ignition warranty.

CAUTION: The aircraft operator has the SOLE responsibility of determining how to appropriately and safely configure and control engine and ignition operation. Nothing stated by E-MAG in this manual, its employees, owners, agents, representatives, or affiliates should be construed as overriding or invalidating the engine manufacturer's instructions. E-MAG has NOT performed testing on the wide variety of engines in popular use and cannot offer specific advice as to proper/suitable ignition configuration.

Notwithstanding engine manufacturer approval of certain engines to burn auto/alternative fuels, such endorsements almost certainly presume operation with fixed magneto timing – and not variable firing electronic ignition. Operators are SOLELY RESPONSIBILITY for independently verifying proper engine behavior with standard and/or alternative fuels including the ignition setup AS CONFIGURED BY THE OPERATOR.

Markings:

- The letter "C" or "L" indicating a model compatible with most Continental™ or Lycoming™ style engines.
- Or a full model number ending with letter C or L indicating compatibility with most Continental™ or Lycoming™ style engines
 - 200-6XC
 - 200-6XL
- Other part numbers may appear in the same area (disregard).

System Serial Number - is etched into the electronics case.

When ignitions are serviced by the factory, a Service Sticker (roughly ¾" x ¾") will be added that shows currently installed circuit board and firmware.

USING THIS MANUAL.....	3
SHORT-CUT	4
INSTALLATION AND OPERATION.....	6
COCKPIT CONTROLS.....	6
CONTROL PLUG WIRING.....	7
SETUP AND CONTROL SWITCHES.....	8
LED AND TONE SIGNALS.....	9
ENGINE ATTACHMENT	9
PLUG WIRES – CYLINDER ASSIGNMENTS	10
AUTO PLUGS AND ADAPTERS	10
MANIFOLD PRESSURE (MAP)	11
SETPOINTS	12
SET IGNITION TIMING.....	12
PULL-THRU TEST	15
TUNING MAX.....	16
OPERATING NOTES	18
MAINTENANCE.....	19
WIRING DIAGRAM.....	21
APPENDIX 1 – SPARK PLUGS & ADAPTERS	23
APPENDIX 2 - DELETED THIS MANUAL	23
APPENDIX 3 – TACH ELECTRICAL SPECIFICATIONS	24
APPENDIX 4 - INSTALLATION CHECKLIST	25
APPENDIX 5: HARNESS FABRICATION (LEADS)	27

Using This Manual

This manual will include supplemental notes, comments, and tips that will appear as *blue* text.

Different versions of this manual are available for Lycoming™ style and Continental™ style engines. Both versions can be downloaded from the E-MAG web site.

Lycoming is a registered trademark of Avco Corporation.
Continental is a registered trademark of Continental Motors Group™.

Exercise care when handling the ignitions, engine, or propeller. There is a significant risk of burn, electrical shock, injury, or even death. This manual may offer safety suggestions, but it is NOT to be considered a complete list of the potential hazards, NOR is it presented as a complete set of safety precautions that should be followed.

RISK OF EQUIPMENT DAMAGE: [*IMPORTANT***]** Firing the ignition without all high voltage loops in place, risks damaging the coils and/or electrical shock to the handler. If incurred, such damage may not be immediately evident. High voltage loops include the circuit from a given coil tower, to plug wire, to plug, to engine block, to companion plug, to companion plug wire, to companion coil tower. Each pair of cylinders (1&2, 3&4, 5&6) constitutes a separate high voltage loop.

ID	Date	Summary of Principal Changes
V 200-6X.31	5/25/19	Initial Product Release - disregard all previous materials. Note: This ignition version includes two operating modes (fixed and variable firing). Both modes share common position and processor-based control logic elements. Redundancy is provided by having two autonomous (left/right) ignitions, and up to three sources of operating power. Experimental versions DO NOT have discrete logic circuitry for each mode.
V 200-6X.38	10/28/19	Simplified Setup procedure. Simplified DIR check and DIR change instructions. MAX factory default now 9 degrees ahead of MIN. Lycoming and Continental engine types now have separate instruction sets. Added Quick-Start overview for re-installing. Numerous other changes.
V 200-6X.39	11/12/19	Added option for straight spark plug boots/terminals if needed – primarily for lower plugs on some Continental engines. Added key parts to confirm prior to installation – see Quick-Start. Reduced many of the required control wire sizes. Revised starting instructions.
V 200-6X.40	7/28/20	Revised LR Denso spark plug number. Mode Switch (optional for normally aspirated engines – 1K resistors are pre-installed in the factory switch Revised routine for changing ignition direction (DIR)

V 200-XC.41	7/21/21	Clarified wording in Setup section.
V 200-XC.42	9/3/21	Correction to recommended LR spark plug stocking number. Tuning tip: Customers reporting improved performance with MAX set 6-degrees ahead of MIN.
V 200-XC.43	5/1/23	Suggestion for long primary battery cable runs (RV10s, canards, others). Clarify: Pull-Thru test verifies bank firing order only. Cannot be used to check tracking accuracy. Revised wiring schematic Firmware V55 and after enables Fixed Mode starting, increased spark energy, Fixed Mode fires at MIN vs previous version Fixed Mode firing at default 20. Factory default MIN will be between 20 and 22 degrees. FW V58 improves transitions from external power off to power on. Manual sections have been reorganized to better follow installation flow.

Short-Cut

(Abbreviated Overview – New installers should review the entire manual.

Prior to installation, make sure you have the following items identified and on-hand.

- Suitable ignition mounting clamps. Some Continental™/Bendix style clamps (#535847) have a shallow reach that will not provide suitable contact surface. Continental™ clamps #630535 (not stocked by E-MAG) have a longer reach and proper thickness – [see Appendix 4](#).
- Fittings needed to connect ignition manifold pressure to your induction system. The included (ignition side) MAP tubing and fittings can be replaced with other styles – installer discretion – [see Manifold Pressure \(MAP\)](#).
- Identify your 14/28/48-volt power connection, fuse or circuit breaker, and power test switch requirements - [see Control Plug, Cockpit Controls, Wiring Diagram](#).
- Suitable automotive spark plugs – [see Appendix 1](#).

*Most Continental™ styled engines rotate clockwise (viewed from back of the engine - looking at prop on the far side). The ignition drive direction (DIR) will depend on the position of the ignition mount in the accessory case. Series 200 6XC ignitions come pre-configured for top mounted (vs. rear mounted) ignitions on clockwise rotating engines. Don't worry - The setup procedure has multiple checks to help installers easily verify, and change when necessary, to insure proper ignition direction (DIR). The first check starts by watching the ignition LED Color-Burst. In the first ½ second after power-up the ignition LED sequence will flash WHITE followed by RED or GREEN, and then resume normal signaling. "C" (Continental™) designated ignitions have a factory default **White/GREEN** Color-Burst – meaning DIR is set for a clockwise engine with overhead mounted ignitions - continued below.*

Before installing ignition - look at the vacant ignition drive socket while turning prop in normal direction. For purposes of checking rotation (DIR) in Step 3 below:
CW rotation indicates you have a RED engine.
CCW rotation indicates you have a GREEN engine.
Note which type you have – red or green engine.

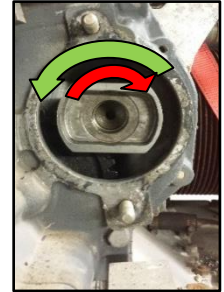

- 1) **Mount Ignition:** Insert the ignition(s) at any convenient orientation and tighten mounting clamps to 17 ft/lb. Verify bus power and kill switches are both OFF, then connect the Control Plug.
- 2) **DIR Color-Burst:** Power ON and watch for the LED Color-Burst code (first 1/2 second). WHITE will be followed by either RED or GREEN. RED engines will want a White/RED burst. GREEN engines want a White/GREEN burst. *(see Setup)*
 - a) If the Color-Burst code matches your engine - proceed to Step 3.
 - b) If Color-Burst code does not match your engine - change DIR – see Note 1 below.
- 3) **TC Setpoint:** Move engine to TC with built-in TC Locator as follows: *(If using other method to locate TC, do so now and skip to Step 4 below. (see Setup for full description)*
 - a) Remove spark plugs and move engine to #1 piston - bottom of stroke. Install Piston Stop tool.
 - b) Verify bus power and Kill Switches are OFF. Press/hold the Config Button, while you turn bus power ON. Continue the hold for six seconds until LED turns BLUE - then release. LED will start blinking BLUE/GREEN to confirm you're in TC Locator mode, where the following processes are enabled.
 - i) Rotate engine to gently arrive at first piston stop – quick-press Button.
 - ii) Reverse engine movement to gently arrive at the second stop – quick-press Button.
 - iii) Remove Piston Stop tool and continue movement in the second stop direction to reach TC, signaled by RED LED with tone.
 - c) Press/hold Button for six seconds, until LED turns WHITE – release button. TC is now stored. Ignition will re-boot in normal mode and settle at YELLOW LED with tone (i.e. TC position).
- 4) **Check or Change MIN and MAX:** Move prop to MIN and MAX positions to confirm or adjust as appropriate *(see Setpoints and Setup):*
 - a) MIN (BLUE LED) matches engine manufacturers recommended magneto firing angle. *Default MIN is in the 20 to 22-degree range.*
 - b) MAX (WHITE LED) marks the maximum cruise firing angle. *Default MAX is 9-degrees before MIN.*
- 5) **Basic Setup is complete.** Finish installing plugs and plug wires, MAP plumbing, blast tube cooling, and do the Pull-Thru test. *See details for each later in the manual.*

Note 1: **Change DIR**

- 1) *(Firmware V52 and after) Position engine so ignition is at the currently stored TC (YELLOW LED with tone), then press and hold Button for 6 or more seconds. The LED will flash red*

during the hold, then flash WHITE (release Button), then automatically re-start with a color-burst (WHITE then RED or GREEN) that signals the new DIR setting. **Changing DIR will restore factory default TC, MIN, and MAX settings.** Return to Setup Step 3.

2) (Firmware prior to V52) Return to E-MAG for firmware update.

After Setup, correct DIR setting is further confirmed by:

- 1) Engine (prop) movement to the region **before** TC will produce MIN and MAX (BLUE/WITE) LED signals and tone sounds at 20 and 25-degrees (reference tones). If instead, they appear in the 20 to 25-degree region **after** TC. – DIR is set for the wrong direction. Correct by changing ignition DIR.
- 2) The Pull-Thru test (highly recommended) will fire plugs **only** when engine is pulled thru in the programmed direction (DIR). Plugs will not fire if the engine is pulled in the wrong program direction. Correct by changing ignition DIR and repeat setup.

Note 2: TIP if installing alone. It may be difficult to press/hold the Config Button and, at the same time, reach the power switch. Disconnect the Control Plug, then turn bus power ON, then press/hold the button while you re-connect the Control Plug (i.e., turn bus power ON).

Note 3: While checking MIN and MAX setpoints you will notice the ignition sounding a tone signal at the 20 and 25-degree positions. They are provided as a positioning aid only. They are fixed and do not move if you change MIN or MAX setpoints.

Installation and Operation

Cockpit Controls

- 1) Circuit breaker or fuse (one per ignition).
- 2) Ignition kill switch can be either:
 - a) Rotary switch OFF/R/L/Both/Start.
 - b) Toggle switch UP/ON and DOWN/OFF.
- 3) Ignition power test switch (*Note 1*) is for testing ignition internal alternator – see *Ignition Checks*:
 - a) Ramp Checks - a basic ignition alternator check.
 - a) Cut-Out test – a stress test for ignition alternator and overall system to determine the low speed operating boundary. Should be done after installation, annual check, and after major maintenance.
- 4) Mode Switch FIX/VAR:
 - a) Required on all boosted engines.
 - b) It is **optional** on non-boosted engines - see wiring diagram at end of manual.

Note 1: The internal alternator power test circuits can be configured several ways and is largely a matter of builder preference. That said, the two controls involved (kill switch and power test switch)

can be located next to each other on the panel, making these tests one-handed, intuitive, and more ergonomic. Two examples are shown below the Wiring Diagram at the end of this manual.

Control Plug Wiring

1) Plug Styles:

- a) Standard circular Mil plug connector (PT06A-10-6S-SR or similar). This is a solder connection style plug with built-in strain relief clamp for attaching (20 AWG) control wires. *Note: Standard plug is roughly 1/2" longer than the optional potted plug (below) - in case clearance is tight.*
- b) Optional circular plug connector with pig tail – circular connector (PT06P-10-6S or similar) with 96" of wire soldered and potted – see color references below and wiring schematic at the end of the manual.

2) Pinouts:

- a) **Pin "A"** on circular plug (**Pig-Tail red wire**) - connects to your 14, 28, or 48-volt aircraft bus – 20 AWG - *see Note 8*. Route through a power test switch and suitable circuit protection. Possibilities are:
 - i) A separate 5-amp fuse and separate power test switch.
 - ii) A 5-amp switchable circuit breaker, which can satisfy circuit protection and power test duties.
- b) **Pin "B"** (**Pig-Tail black wire**) - connects to the cockpit panel ground – 20 AWG.
- c) **Pins "C" and "D"** (**Pig-Tail white and green**) – stow for future use – 22 AWG.
- d) **Pin "E"** (**Pig-Tail yellow wire**) - connects to your cockpit kill switch (p-lead ignition ON/OFF). To turn ignition OFF, ground the p-lead with the switch. To turn ignition ON, un-ground the p-lead Kill Switch (*) 22 AWG.
- e) **Pin "F"** (**Pig-Tail blue wire**) – connects to tach instrument (3 pulses per rev) 22 AWG

(*) *Mode Switch (optional): Ignitions can work with a cockpit switch to select either Fixed Mode or Variable Mode operation. The switch circuit adds a 1K bias signal to the existing kill wire (pin E) to enable Fixed Mode operation. The switch E-MAG offers is a SPDT (one switch controls two ignitions) with 1K resistors pre-installed. Mode Switch is optional on normally aspirated engines but is required on boosted engines.*

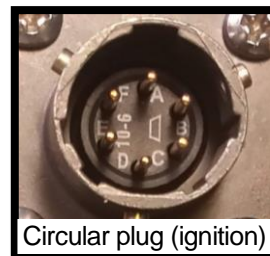

Circular plug (ignition)

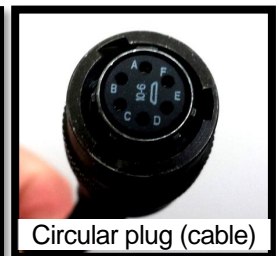

Circular plug (cable)

*Note 1: Shower or vibrator type starting aids are **not compatible** and may damage your E-MAG – remove before installation.*

Note 2: E-MAG p-lead wire does not make radio noise and does not require shielding. If replacing a magneto, your existing shielded p-lead wire can be re-used. If doing so, the outer shield needs to be trimmed clean and kept well clear of all other terminations.

Note 3: All E-MAGs are "starting ignitions". In a dual installation, or if replacing a non-starting

magneto, revise your starting procedures, and/or remove any key switch starting blocks (remove the jumper on the back of the key switch) to your E-MAGs.

Note 4: Whenever the aircraft bus is powered ON, the ignition is “awake”. It draws a small amount of current (approx. 40 milliamps) even when not firing plugs. Use the master bus switch (or breakers if necessary) to power down the ignitions when not in use.

Note 5: Do not power the ignition ON when you have a ground battery charger connected to the bus. Pulling the breaker will isolate the ignition when charging.

Note 6: Collect your tach signal from only one ignition unless your instrument has provisions for two (separate) tach inputs. Unlike a magneto, E-MAGs produce a tach signal even when kill switch is turned to OFF.

Note 7: Tach signal is a 3 pulse/rev, low true, 33% duty cycle, 10-12-volt pulse - see Appendix 3.. E-MAG’s tach output is a courtesy feature, unrelated to the ignition’s primary purpose. Due to the variety of instrument options available, our ability to support and troubleshoot interface issues is limited.

Note 8: Longer cable runs to a remote main battery* may need to access bus power through a dedicated 16 AWG cable connected directly to the battery. This will avoid sharing a long power cable with the starter motor, a combination that can exaggerate power dips during startup and inhibit ignition operation when cranking.

*Typical in RV10s, some canards, and others.

Setup and Control Switches

- 1) **Configuration Button** (“Button”) is located beneath a black plastic screw cap on the end face of the ignition. The Button is used to set TC, move MIN/MAX setpoints, or change ignition DIR.
- 2) **Mode Switch** (optional) – Fixed Mode or Variable Mode can be selected by a single cockpit Mode Switch that directs both left and right (Series 200) ignitions. Fixed Mode is enabled when the Mode Switch applies a 1K bias resistance to the kill circuit(s). The Mode Switch can serve one or two (Series 200) ignitions. *The Mode Switch is **required** for all boosted engines. For non-boosted engines the Mode Switch can be eliminated, in which case the ignition will operate in Variable Mode only.*
 - a) **Fixed Mode** - Mode Switch “FIX” will fire plugs at the MIN firing position. *RPM must be above cranking speeds – i.e. you cannot start in Fixed Mode. [In FW V55 and after, Fixed Mode starting is enabled]*
 - b) **Variable Mode** - Mode Switch “VAR” allows RPM and MAP inputs to select a plug firing position between the MIN and MAX boundaries.
- 3) **Power Test Switch** - A cockpit power interrupt switch will be used to test the ignition internal alternator. A switchable circuit breaker or separate test switch can perform this function. – *see Wiring Diagram*
- 4) **Kill Switch** (p-lead switch) - The traditional cockpit ignition ON/OFF (Left/Right) test switch is unchanged. The Mode Switch does not interfere or alter Kill Switch operation. The Kill Switch

OFF position connects the E-MAG kill wire (p-lead) to ground. The ON position un-grounds the kill wire. *Note: All other connections from previous installations (tach, shower of sparks, etc.) must be removed from kill switch wiring.*

LED and Tone Signals

- 1) **RED LED indicates CAUTION.** When ignition is powered ON and kill switch is ON the unit is capable of firing plugs (“HOT”).
 - a) Steady RED indicates Variable Mode HOT.
 - b) Blinking RED indicates Fixed Mode HOT.

- 2) Other LED colors are enabled by turning kill switch to OFF (ground p-lead). Plug firing is blocked when displaying other colors.

- a) Background color is GREEN.
- b) Setpoints:
 - i) **YELLOW*** (with tone) signals ignition TC setpoint.
 - ii) **BLUE** signals MIN setpoint, the lower end of the firing range in Variable Mode or the fixed firing position in Fixed Mode.
 - iii) **WHITE** signals MAX setpoint, the upper end of the Variable Mode firing range.

- 3) Tone will sound at:

- a) The stored ignition TC position (with YELLOW LED).
- b) Ignition 20 and 25-degree positions. Tones are for the sole purpose of helping installers locate their chosen MIN and MAX setpoints. After setting TC, these tones will flag the 20 and 25-degree positions – see Fig A. Other positions (18, 22, 35, etc.), if needed, can be interpolated from these fixed reference locations.

* **YELLOW** is a composite color where LED elements produce a dull and slight shimmering yellow effect.

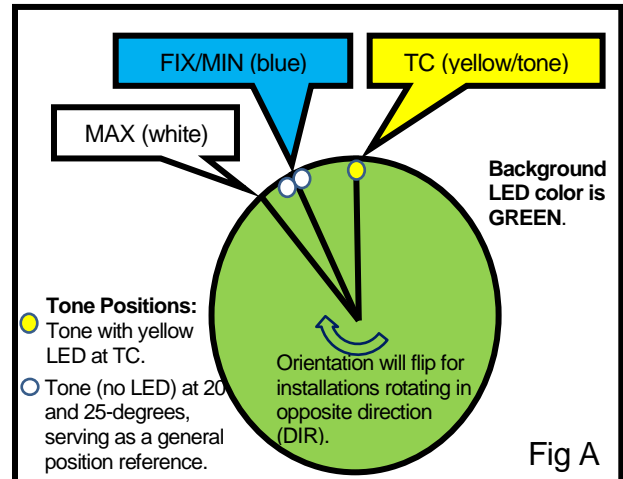

Engine Attachment

First, verify the clamps you have are suitable for the E-MAG flange. E-MAG flange is 0.19” thick - not suitable for 0.31” clamps.

- 1) Two studs, one above and one below each ignition station.
- 2) Mounting clamps fit over each stud to secure the ignition flange (and fiber gasket) to the case. Alternately tighten upper and lower clamp (nuts) to 17 ft/lb. *Note: Some Continental™/Bendix style clamps (#535847) have a shallow reach that will not provide suitable contact surface. Continental™ clamp #630535 (not stocked by E-MAG) have a longer reach.*

Plug Wires – Cylinder Assignments

As with any wasted-spark ignition, E-MAGs fire spark plugs in pairs. Cylinders 1&2, 3&4, 5&6 are pairs with plug leads connected to both ends of a double ended coil “Bank”. See Appendix 5 for instructions on fabricating individual trim-to-fit plug wires.

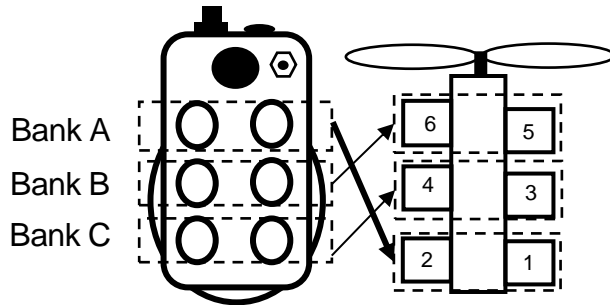

Continental™ engines:

- 1) Always - route Bank A to cylinders 1&2.
- 2) Most installations will route Bank B to 5&6, Bank C to 3&4 as shown.
- 3) *In the event of a Left (CCW*) rotating engine* (i.e. for a twin) you may need to swap Bank B and C assignments

Always verify proper firing with the Pull-Thru test.

*Note 1: The Pull-Thru test [highly recommended] is the best way to verify the installation follows correct bank (cylinder pair) firing order. This test uses encoder data at the lowest possible resolution, i.e., **pull-thru firing positions cannot be used to check tracking accuracy**. During normal operation, dynamic quadrature counters are used to increase tracking resolution and accuracy.*

Note 2: Ignition Bank firing sequence is A-B-C regardless of the direction of the engine/ignition drive interface.

*Note 3: * CW and CCW engine rotation reference – as viewed from back of engine looking to prop on the far side.*

Note 4: If using strap (Adel) clamps to secure plug leads, make sure the clamps are properly sized. Reusing clamps for smaller size (previous) wire may be too tight and crush/compromise the internal silicone insulation layer of our 8mm wire.

Auto Plugs and Adapters

Aircraft engines are typically tapped for 18mm thread spark plugs. To use 14mm automotive style plugs, we sell Auto Plug Adapters. There are numerous auto spark plug styles and temperature ranges available through various outlets. E-MAG has NOT studied the relative durability or performance of different plugs. Customers need to monitor plug condition and evaluate and adjust as necessary. The plugs listed in Appendix A and have a history of good service. Set plug gaps at 0.030” to 0.035”.

Long Reach (LR) vs. Short Reach (SR) Cylinders

Cylinders are made with two different spark plug thread depths. Match spark plugs and plug adapters to the cylinder depth when ordering.

- 1) LR or SR cylinders can be identified by the aircraft spark plug call-out for the particular engine. If it has the letter “M” - as in REMXXX, you will need SR plugs and adapters. If it has the letter “B” as in REBXXX, you will need LR or LRX plugs and adapters.
- 2) The thread lengths of plug adapters are as follows:
 - a) Short Reach (“SR”) external threaded section is approx. 1/2”.
 - b) Long Reach (“LR” and “LRX”) external threaded section is approx. 3/4”.



*LRX adapters have extended hex heads to facilitate removal from some certain engines (550s and maybe others) where the plug seat area is recessed and too tight for standard sockets. **When needed, you must specify LRX adapters when ordering.***

Spark Plugs - See Appendix 1 for specific spark plug recommendations.

IMPORTANT: Remember to FIRST install each spark plug in the adapter (fully seated and finger tight). THEN, insert the combined plug/adapter assembly in the engine and tighten to 18 ft/lb (standard auto plug torque) through the spark plug ONLY. Do NOT torque the adapter itself. If you torque the adapters directly, stress will be focused underneath the adapter head, and it can fail during installation. Such failures are not covered under warranty. Use anti-seize (sparingly) on the outer/engine side of adapters. Auto plug manufacturers do not recommend anti-seize on their plugs.

Manifold Pressure (MAP)

The ignition comes with 3’ of 1/8”x1/4” silicone tubing, and a 1/8” barbed nipple to 1/8” NPT brass fitting (packed separately), for use in connecting manifold pressure. You could also use the female 1/8” NPT in the ignition to attach your own larger MAP hardware if preferred. The ignition has both electronic and mechanical MAP pulse dampening built in.

Normally aspirated engines: With normally aspirated engines, the MAP tube is a fail-safe input. Meaning if the MAP plumbing comes loose or fails, plug firing in Variable Mode will automatically retard to a very flyable, but slightly less efficient, firing position. If installing two ignitions, run a single MAP tube to the accessory area, and then tee the MAP line to each ignition. If you have a manifold pressure gauge, tee into that existing line for your pressure source.



Boosted engines: With turbo normalized or boosted engines, **MAP plumbing is NOT considered fail-safe.** A MAP plumbing failure can, in certain conditions, call for more ignition advance than is

appropriate or safe. Excess advance can result in loss of power, overheating, and/or damage to the engine. For this reason:

- 1) The MAP plumbing for two ignitions should be separate. A plumbing failure on one side would affect one – not both ignitions.
- 2) The cockpit **Mode Switch** (required for boosted engines) is a simple and effective override that will bypass the MAP input (plumbing failures) and set the ignition to Fixed Mode firing (where MAP input is not a factor) – see Mode Switch elsewhere in this manual.

Setpoints

(Reference drawing Fig A)

- 1) **TC** (YELLOW LED - with audible tone) signals the ignition top center position.
- 2) **MIN** (BLUE LED) – A firing reference set to match engine mfg. recommended (magneto) firing angle - typically 20 to 25 degrees before top center:
 - a) Marks the low advance (high power) end of the firing range in Variable Mode.
 - b) Also marks the fixed firing position in Fixed Mode.
- 3) **MAX** (WHITE LED) – A firing reference that marks the high advance (cruise power) end of the Variable Mode firing range. The default setting for MAX is 9 degrees ahead of MIN. Can be set anywhere between 6 and 9-degrees before MIN.
- 4) **DIR** (not a setpoint per-se) – *The ignition's current operating direction (rotation) is confirmed by various means throughout the installation process. (i.e. if it's wrong the system will catch it later.)*

*Note 1: Anytime you move a TC, MIN, or MAX setpoint, reconfirm the stored setpoint positions of all three. Some changes will restore the original factory default (override the custom setting you last made). **Setpoints should be stored in order – TC, then MIN, then MAX as shown throughout the manual.***

Set Ignition Timing

Factory rotation direction (DIR) will be pre-configured for overhead mounted ignitions, but it needs to be confirmed. DIR is checked at several points during the Setup process and is easy to change when/if needed. The first opportunity to check DIR is prior to insertion. Look directly into the vacant accessory case ignition drive opening while turning the prop in the normal direction. If the ignition drive socket turns:

- Clockwise - you have a RED engine (DIR color).
- Counterclockwise - you have a GREEN engine (DIR color).

- 1) **Mount Ignition:** Verify bus power is OFF and Kill Switch is OFF (grounded). Turn ignition rotor by hand to align rotor lugs with rubber cushions in the ignition drive socket. Insert the ignition (with gasket) and secure mounting clamps finger tight. Rotate the ignition to any convenient orientation and then tighten mounting clamps to 17 ft/lb.
- 2) **DIR Color-Burst:** Verify bus power and Kill Switches are all OFF. Connect the ignition circular Control Plug and then turn bus power ON. LED will provide a Color-Burst sequence (in the first

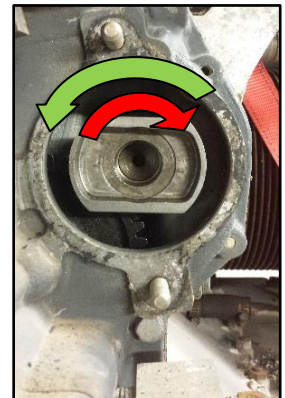

½ second) that ends with WHITE, followed by either RED or GREEN, and then transition to normal color signals. RED engines will look for a white/RED color burst. GREEN engines will look for a white/GREEN color burst. Turn bus power OFF.

- a) If the DIR Color-Burst matches your engine - proceed to Step 3. If it doesn't - change DIR – *see Note 1 below.*
- 3) **TC Setpoint:** Storing ignition TC Setpoint first entails moving the engine to its TC position. Other methods (*Note 1*) can be used, but we recommend the procedure below. *If using other methods, do so now and skip steps a) and b) ii, iii, iv [*keep b)i) and b)v)].* Otherwise, locate and store ignition TC as follows (TC Locator mode):
 - a) Remove spark plugs from Bank A cylinders #1 and #2. *Engine movement will be easier and safer if you also remove one plug from each of the other cylinders.* Move the engine so piston #1 is near bottom of the stroke. *No need to track #1 compression – either stroke will work.* Insert the threaded piston stop tool in either plug hole of cylinder #1.
 - b) Verify bus power and Kill Switches are both OFF.
 - i) ***Enter TC Locator mode:** Press and hold the Config Button while you turn bus power ON. Continue hold (roughly six seconds) until LED turns BLUE - then release. The LED will turn BLUE with a periodic GREEN pulse, confirming you are now in TC Locator mode where the following interactions are enabled.
 - ii) Slowly rotate the prop in either direction until the piston gently contacts the stop (first stop). Quick-press the Button and the LED will switch to GREEN with a periodic BLUE pulse.
 - iii) Slowly rotate prop in the other direction until the piston gently contacts the stop (second stop). Quick-press the Button and the LED will switch to steady GREEN, indicating the ignition has calculated the TC (and 180-degree) positions. Keep bus power ON.
 - iv) Remove the stop tool. *Backing the prop (piston) away from the stop will make it easier to unscrew.* Then continue prop movement in the last (second stop) direction. The LED will turn RED and sound tone (RED/tone) when you arrive at engine TC position.
 - v) ***SET TC:** Press/hold the Button for six (6) seconds and the LED will flash WHITE - release button. TC is now stored, and the ignition will automatically re-boot in normal mode. The LED will settle at steady YELLOW (with tone), indicating the ignition is at the stored TC position.

Note 1: Other methods to locate TC include the manufacturers “flower pot” method or move engine to match TC of a previously set E-MAG on the other side.

4) **MIN (BLUE) and MAX (WHITE) setpoints:**

- a) Check setpoints by positioning prop (engine) to the MIN and then the MAX positions. *Approaching setpoint positions with engine moving in the normal direction may help to reduce gear lash*
 - i) Confirm the MIN(BLUE) setpoint matches the engine manufacturers recommended magneto firing angle. *NOTE: Engine alterations that boost power (high-compression pistons, induction mods, custom cams, enhanced fuels, etc. may require more conservative (lower) MIN and MAX settings. The ignition default MIN is around 20 to 22-degrees before TC. Adjust as needed.*
 - ii) MAX(WHITE) *The ignition default MAX is 9-degrees ahead of MIN and can be re-set as low as 6-degrees ahead of MIN.*

- b) Change setpoint positions (if needed) – *see Note 5*:
 - i) With the intended **setpoint color showing** (BLUE example) press/hold the Button.
 - ii) Continue the hold while you move the prop (engine) to the desired setpoint location.
 - iii) Then release the Button. The LED will remain (BLUE example), indicating placement at the newly stored setpoint.
- 5) **Basic setup is complete. Always** confirm setpoints by rocking the prop back and forth over:
 - a) TC Setpoint to see GREEN – YELLOW/tone - GREEN - *see Note 1*.
 - b) MIN Setpoint to see GREEN - BLUE – GREEN - *see Note 1*.
 - c) MAX Setpoint to see GREEN - WHITE – GREEN

Prior to operation you need to connect plugs and plug wires, manifold pressure (MAP) plumbing, and blast tube cooling – as appropriate. We also recommend doing a Pull-Thru test. Details for each can be found elsewhere in manual.

Note 1: After Setup, correct DIR setting is re-confirmed by:

- *Engine movement in the region before TC will produce MIN (BLUE) and MAX (WHITE) LED signals and tone sounds at 20 and 25-degrees (reference tones). If instead, they appear in a similar region after TC. – DIR is set for the wrong direction. Correct by changing ignition DIR – see below.*
- *The Pull-Thru test (highly recommended) will fire plugs **only** when engine is pulled thru in the programmed direction (DIR). Plugs will not fire if the engine is pulled in the wrong program direction. Correct by changing ignition DIR.*

Change DIR

- *(Firmware V52 and after) Position ignition at TC (YELLOW LED with tone), then press and hold Button for 6 or more seconds. The LED will flash red during the hold, then flash WHITE (release Button), then automatically re-start with a color-burst (WHITE then RED or GREEN) that signals the new DIR setting. **Changing DIR will restore factory default MIN, MAX, and TC settings.** Return to Setup Step 3.*
- *(Firmware prior to V52) With a steady GREEN LED showing (normal background color), press/hold Button for 10 seconds until the LED turns WHITE – release Button. Ignition will store the change and re-start with a color-burst (WHITE then RED or GREEN) that signals the new DIR setting. **Changing DIR will restore factory default MIN, MAX, and TC settings.** Turn bus power OFF and return to Setup Step 3*

*Note 2: Make sure Kill Switch stays OFF until all high-voltage connections (plugs, plug-wires, coil) are in place. Firing plugs without all high-voltage connections risks damaging the coil. After the initial Color Burst at power-up, a continuous RED LED (flashing or steady) indicates ignition is ON/HOT (ready to fire plugs). **No Setup procedure requires ignition to be HOT.** Power OFF and examine/correct kill circuit.*

Note 3: Take care with the rubber drive socket cushions when removing or inserting the ignition. If they drop into the accessory case, retrieval can be problematic.

Note 4: Moving MIN or MAX Setpoints. The procedure for moving a MIN or MAX setpoint is simple but strict in two respects:

- Make certain the Button press/hold is started with the **setpoint color showing** (BLUE or WHITE) (i.e. not the background GREEN color).
- The “hold” must be uninterrupted until you reach the new engine position. If the Button hold is relaxed in route, the setpoint will attach to an unintended release point.

Note 6: Top center and other engine position markings (TC, 20, 25, etc.) may be stamped on the prop flange that will align with the lower engine case seam – see engine manufacturers documentation.

Blast Tube Cooling

E-MAGs are designed for a high-heat environment, but there are still thermal limitations and benefits to keeping the equipment as cool as possible. Blast tube cooling is a simple way to reduce operating temperatures, and we consider it mandatory (not applicable to top mounted installations on the cold side of the engine deck). Blast tubes should be directed at the round neck, immediately behind the mounting flange.

The mere presence of blast-tubes does not guarantee they are operable and/or effective. After initial operations, operators can verify the ignitions are within temperature guidelines (under 200F during flight). A thermal reactive label is installed on the electronics case. Alternatively, a thermal probe can verify ignition case temperatures at the forward section of the electronics (box shaped) compartment.



Electrical System Condition

E-MAG’s power dip protection helps guard against severe voltage drops that occur when the starter motor is engaged. However, in the event of a compromised electrical system (low battery, long cable runs, corroded terminals, cold engine, etc.) bus voltage may not rebound as the starter speeds up (as is normal). A properly designed and functioning electrical system is essential for the ignition to work properly. If bus voltage goes below safe levels while cranking, a built-in power dip safety circuit will not allow the ignition to fire (per design). The starter is the largest load on the electrical bus. Keeping non-essential loads turned OFF while cranking will help. *Note: We have no definitive guidance, but there is some indication light-weight lithium batteries may contribute to greater ignition voltage dips during startup.*

Pull-Thru Test

The Pull-Thru test will confirm 1) plug wire assignments, 2) basic operation of firing circuits, and 3) correct DIR as follows:

1. Remove all spark plugs from the engine and reconnect them to the plug leads.
2. ***IMPORTANT*** Rest each plug on the engine case or convenient location such that the metal jacket of each plug is grounded to the engine block. *Alternatively, the plug metal jackets can be wired to the engine block or plugs can be bundled directly to each other with metal jackets in direct contact of each other.*

3. One ignition at a time: Turn bus power ON, Kill Switch ON, and (if installed) Mode Switch to VAR. LED will be steady RED. Rotate the prop by hand in the normal direction of travel and confirm all plug pairs fire in proper sequence. Any deviation indicates a wiring or setup error.
 - Both plugs for cylinders 1&2 (Bank A) fire at the starting lag position (4 degrees after TC).
 - Both plugs for Bank B fire 120 degrees later – see Note 3.
 - Both plugs for Bank C fire 240 degrees later – see Note 3.

Note 1: Plugs will not fire:

- i) When the engine is rotated the wrong direction.*
- ii) If ignition DIR is not configured to match engine rotation.*
- iii) When Mode Switch is in FIX position and engine is moving at hand pull-thru speeds.*
- iv) Plugs fire only once per cycle. You cannot back up and fire them again. Keep pulling thru in the normal direction.*

Note 2: Multi-Strike. At cranking speeds, the ignition uses a (5) rapid strike sequence for each bank. This means the Pull-Thru Test will not produce the familiar single spark “click”. Instead, you’ll hear the plugs “buzz” - the sound of a multi-strike sequence.

Note 3: Due to the variety of engine and ignition configurations, it may be necessary to swap the plug wire to cylinder (Banks B and C) assignments to achieve proper firing – per the engine manufacturer firing order.

Note 4: Pull-Thru firing positions cannot be used to verify ignition tracking accuracy. It only confirms proper wiring and circuit assignments.

Tuning MAX

Orientation:

Operating the ignition in Variable Mode (Mode Switch “VAR”) can improve engine efficiency by enabling automatic adjustment of the plug firing advance. The range of automatic adjustment is capped by the MAX setting. MAX will be either the default (9-degrees ahead), or a lesser MAX position (as low as 6-degrees ahead) as set by the operator.

TIP: Most Cont 550 customers are reporting improved cruise performance with MAX setting reduced to 6-degrees ahead of MIN (vs. the 9-degree default).

Operators can monitor VAR mode cruise conditions (RPM above 2400 and MAP 22” or below) where spark advance is greatest and be mindful of the engine manufacturer’s temperature recommendations and red-lines. It should be understood that improving efficiency (extracting more energy from a given amount of fuel) means a certain amount of additional heat may be generated.

Operators can anticipate VAR mode advanced firing to cause CHTs to rise by some increment and EGTs to fall by some increment.

As a **GENERAL FRAMEWORK ONLY**, VAR mode operations (MAX adjustments) can be guided by engine efficiencies (airspeed/fuel-flow) and CHTs at cruise power settings – keeping in mind the limitations of CHT readings. Ignition advance is a significant, but not the only factor influencing CHTs. Baffling, mixture, prop, cylinder design, cylinder break-in, air temperature, air density, humidity, fuel type, induction boost, and more can all affect the indicated CHT. Every installation should be considered unique – assume nothing.

Establish a baseline

An initial period of operation in Fixed Mode (Mode Switch to “FIX” after start-up) will allow you to establish an operating baseline with plug firing at the manufacturer’s recommended (magneto) firing position. Similarly, Variable Mode operation at high power (higher RPM and MAP 25” and above) settings will fire at the same MIN/magneto position. The ignition will still provide higher spark energy and that alone can have some effect on engine behavior. If temperature issues are encountered under these conditions you might test with a slight reduction of MIN firing position, or look into correction outside the ignition – baffling, fuel, etc.

Tuning Actions – Adjust MAX setpoint (affecting Variable Mode only)

- 1) Extending MAX past the 9-degree default will offer little additional benefit. The underlying advance table itself (initial release models) is limited to 9-degrees. The ignition may reject attempts to set MAX past this point.
- 2) Restricting MAX (move closer to MIN) will cap the advance range which should reduce excessive cruise CHTs – if encountered. *Note: Cont 550, and perhaps others, seem to favor MAX setting closer to 6-degrees ahead of MIN.*

Tuning Objectives:

The goal is not to deploy the maximum amount of ignition advance possible. Rather, we’re looking for the least aggressive range that maximize performance - and no more. Overly aggressive settings don’t improve performance, but can increase temps and potentially damage the engine. Adjust accordingly.

Note 1: Mode Switch - When you enable Variable Mode (Mode Switch “VAR”) to test MAX settings, you always have the option of switching to Fixed Mode (Mode Switch “FIX”) and return to your previously established fixed firing baseline. The Mode Switch can be operated at any time, other than startup, when Variable Mode is required.

Note 2: Alternative (auto) Fuels: CAUTION - Notwithstanding engine manufacturer approval of some engines to burn auto/alternative fuels, such approvals almost certainly presume operation with fixed magneto firing - not high-energy variable firing electronic ignition. Operators need to independently validate proper engine behavior with different fuels and adjust ignition as needed. Generally speaking, auto fuel burns faster than avgas and is, in effect, a timing change. An offsetting adjustment (lower advance) may be necessary for proper operation.

Operating Notes

Mode Switch

Start engine with Mode Switch set to VAR (plugs will not fire at cranking speeds in FIX Mode). **[Ignitions with FW V55 and after Fixe Mode starting is enabled]**. The Mode Switch does NOT replace or interfere with traditional ignition ON/OFF (p-lead/kill) switches. Rather, it's a simple in-flight control that switches between Fixed Mode (ON) and Variable Mode (ON).

Engine Management

The high energy spark and variable firing of an electronic ignition will change engine behavior.

Starting:

- 1) **Flooding** can occur when excess fuel is introduced in the cylinders and is an issue for all types of ignitions. High energy spark is more resistant to flooding, but there are limits to how much can be tolerated.
- 2) **Wasted spark** ignitions (E-MAG and others) fire spark plugs in pairs. On any given cycle only one cylinder, within a Bank pair, is in the compressed "firing" position. At that same moment, the companion cylinder is between the intake and exhaust strokes with both valves open. A wasted spark ignition will fire plugs in both cylinders within the bank. If sufficient fuel vapor is present in the companion cylinder due to excess priming, throttle, mixture, or any other reason, the companion chamber can ignite. This is called a "wasted side firing" and can send a pressure pulse down the intake and exhaust pipes. It's sometimes mistaken as a backfire or a kick-back, which is different. Wasted side firing is remedied by adjusting your starting procedure to reduce excess fuel.

To reduce the risk of both flooding and wasted side firing, **we recommend you begin your search for optimal start-up settings on the extreme lean side** and **gradually** modify (increase throttle or mixture) as necessary to achieve quick and consistent starts.

Lean-limit and mixture control: The familiar lean-rough boundary experienced with magnetos will shift (far leaner) or it may disappear entirely. This significantly alters the lean-rough boundary and the seat-of-your-pants mixture control (lean to rough- then richen).

Ignition Checks: Your ignition checklist will be extended to include two new features, internal alternator and Mode Switch (if installed). Both can be tested during your routine left/right Ramp Check, but the alternator has an additional test (Cut-Out test) that is run on a different schedule.

- 1) Ramp Checks (roughly 1700 RPM):
 - a) Internal Alternator - E-MAG internal alternator operates in parallel with power supplied by the aircraft bus. The ignition automatically transitions between aircraft power and internal alternator power as needed. Aircraft power is required for starting and sometimes for low idle speeds.
 - i) Running on one side only, turn ignition power test switch OFF for 2-3 seconds and back ON. The engine should run smooth during the outage – this verifies the internal alternator is working.
 - ii) Repeat with the other ignition.
- Any rough or degraded behavior indicates a problem - not suitable for flight.

- b) Mode Switch (recommended, on all boosted engines) – Mode Switch will be set to VAR for most operations and is **required** for starting.
 - i) Running on one side only, turn Mode Switch from VAR to FIX for 2-3 seconds and then back to VAR. The engine should run smooth in both positions. The firing position may change with Mode Switch transitions, so a slight shift in rpm might be expected.
 - ii) Repeat with the other ignition.
 Rough or significantly degraded behavior indicates a problem - not suitable for flight.

- 2) Cut-Out test should be done after initial installation, power plant maintenance, and at annual inspection:
 - a) The Cut-Out test checks ignition condition and the entire system (see Note 1) in challenging conditions. Internal alternator output will vary with engine rpm. You are verifying the system is capable of operation without aircraft power at speeds below your in-flight idle. Your ground idle can go much lower than your flight-idle, so the Cut-Out test is a ground based (only) exercise.
 - b) Operating on one ignition, lower engine speed to 1200 rpm. Then cut bus power to the ignition. A slight rpm dip may be expected with lower spark energy.
 - c) Very slowly lower the engine rpm until the engine reaches low idle limit or quits. A log-book entry can help track Cut-Out trends over time.
 - d) Repeat Cut-Out test on the other ignition and then with both ignitions.

Note 1: The Cut-Out test marks the low-speed boundary of the entire system (not just the ignition) when the ignition is self-powered. Spark energy is a significant, but not the only factor affecting cut-out speeds. Mis-adjusted idle mixture fowled or partially fowled plugs, induction leaks, mis-adjusted prop, and other factors can affect (elevate) cut-out speeds. Keep this in mind if ever investigating the cause of elevated cut-out speeds. E-MAG bench tests every ignition to verify they self-power, open air spark, down to 700 rpm prior to shipment. This is well below most in-flight idle speeds.

Note 2: When performing a Cut-Out test, if the engine falters allow it to come to a stop and fully power down. Re-applying bus power or activating the other ignition at the last moment to keep the engine running may not restore full operation and is unlike the power boundary event we are probing.

Maintenance

Condition Inspection (annual)

- 1) Confirm Setup reference positions (TC, MIN, MAX) prior to removal. Look for discrepancies (if any) from prior settings.
- 2) Check E-MAG web site for the most recent Manual (www.emagair.com/downloads), Service Notes (www.emagair.com/service-notes), to verify equipment is current with all updates.
- 3) Ignitions come with a thermal sticker that will trip (turn from a light eggshell white color to gray or gray/black) as case temperatures exceed 200 degrees (F). Dark gray or solid black indicates a

period of significant over-temp. If tripped, review blast cooling and/or other cooling impediments. Operating temperatures should, but are not required, to be kept below 200 degrees.

- 4) Ohm Check all plug wires and examine for evidence of wear or chafing. Lead resistance should be roughly 180 ohms per foot of wire for wire with no "F" markings. Newer wire sets will measure roughly 40 ohms per foot and will be marked "F40" at intervals along the wire.
- 5) Remove and inspect spark plugs for signs of unusual wear or build-up. Replace plugs at 125 hrs. Re-gap plugs per instructions. When re-installing auto style plugs with auto plug adapters, review plug/adaptor installation guidelines. Ref. Appendix 1.
- 6) Remove ignition and examine shaft for bearing play – *disassembly of ignition is not necessary*. Look for excessive radial and axial play. Shaft rotation should be free, with no catching, flat spots, or grinding. While you have access, inspect the ignition drive cushions which may get hard over time.
- 7) Reinstall the ignition - see Setup instructions.
- 8) Verify proper operation including:
 - a) Perform Ignition Checks on each ignition – see Ignition Check section for guidelines:
 - i) Basic internal alternator Ramp Check.
 - ii) Internal alternator Cut-Out test – record results in logbook for L, R, Both. Mode Switch Check, if installed.

Wiring Diagram

- Power and Ground 20 AWG, all others 22 AWG
- Colors refer to optional pre-assembled cable.

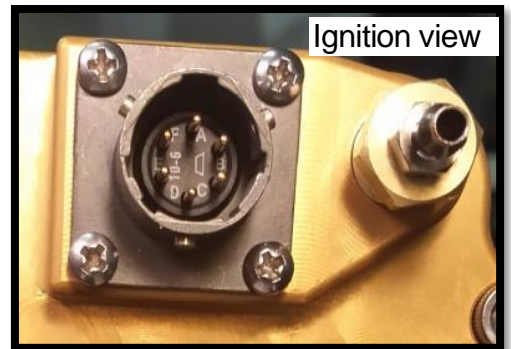
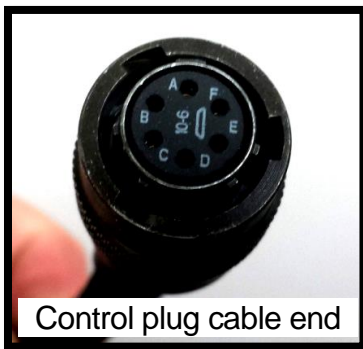
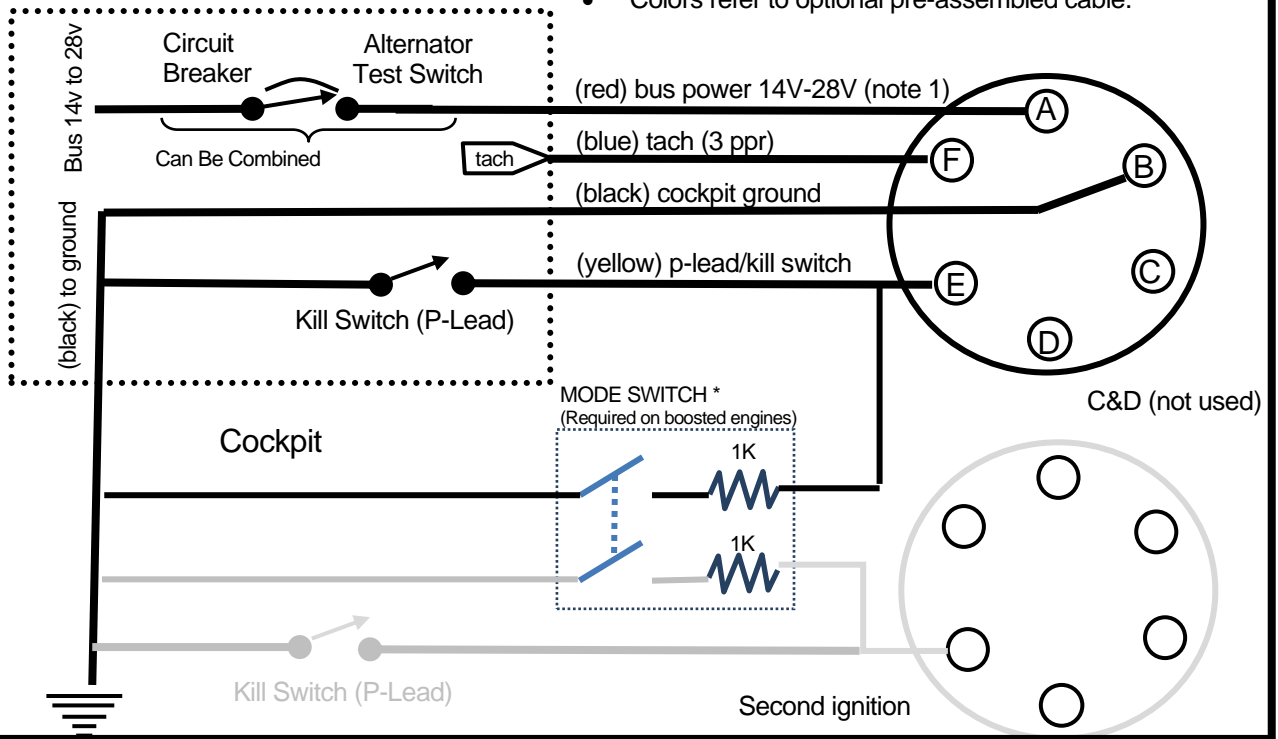

[left] Solder cup pins on back of standard control plug. Pin orientation matches the schematic above and is marked on the inner face of the plug itself. When assembling the Std. connector, remember to pre-position wires thru the strain clamp, plug shell, and shrink wrap before soldering.

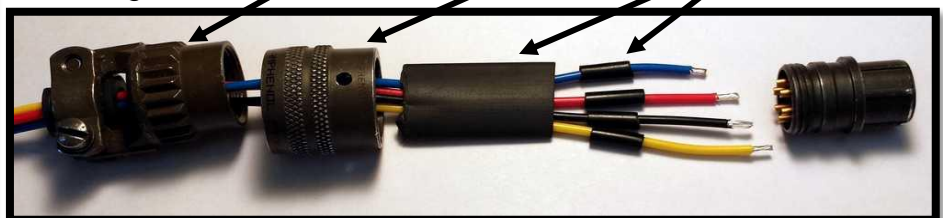

Note 1: Long power cable runs to a remote main battery* may need to route ignition bus power through a dedicated 16 AWG cable to the battery. This avoids sharing a long power cable with the starter motor, a combination that can exaggerate power dips and inhibit ignition operation while cranking. Low battery, cold temperatures, small cable size, poor terminations, etc. can induce a similar affect.

* Typical in RV10s, some canards, and others.

Note 2: The power test switch lets the operator turn aircraft power OFF for testing the ignition internal alternators – see Operating Notes and Ignition Checks earlier in the manual. The power test switch can be configured several ways and is largely a matter of installer/operator preference.

- 1) If using switchable circuit breakers (vs. fuses) the breaker itself can be used as a power test switch - one breaker per ignition.
- 2) A dedicated power test switch can also be used. One such implementation to consider is a momentary push button switch (non-latching, normally closed – push to open, one switch per ignition) that offers the following advantages:
 - a) A push button is not likely to be mistaken, by sight or by feel, for other switches.
 - b) It cannot inadvertently be left in the OFF position.
 - c) It can be located close to kill switch for ergonomic one-handed operation.
 - d) Can pair with either key switch or toggle switches as shown below.

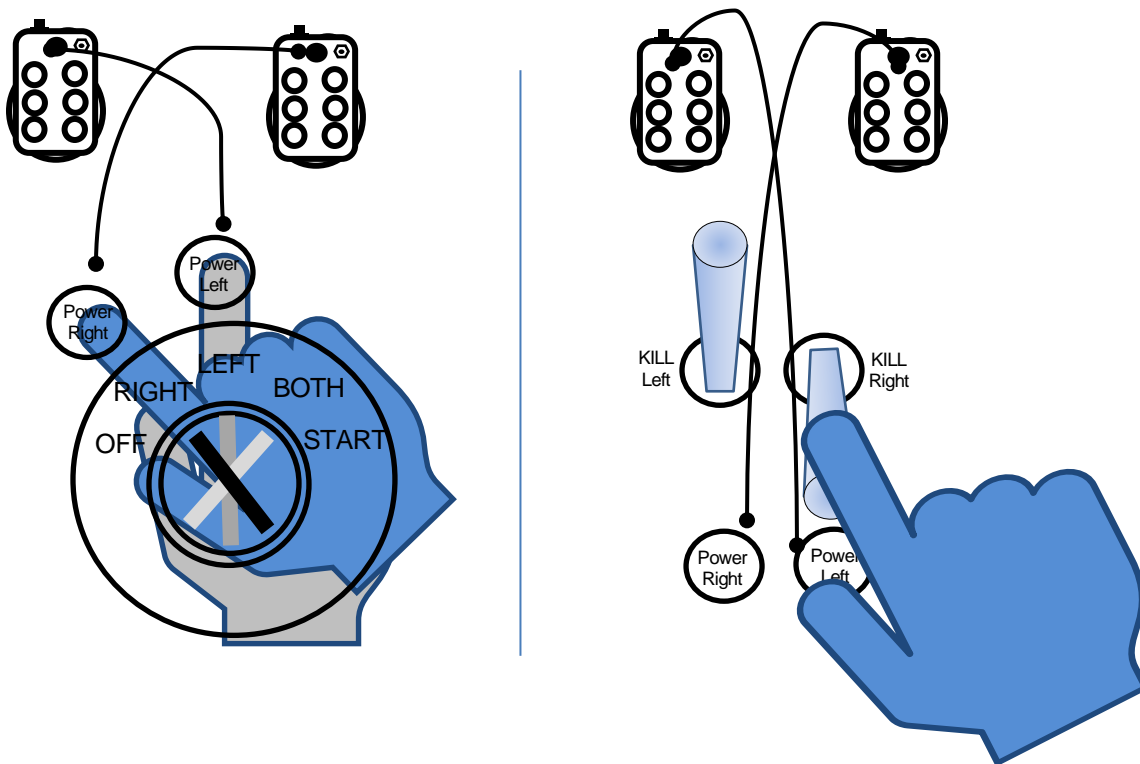

Appendix 1 – Spark Plugs & Adapters

Short Reach Plugs (uses SR plug adapter)

- 1) NGK Spark Plug BR8ES 2.5mm center electrode. Stock #3961 has a solid terminal tip (preferred). Stock #5422 has a screw on tip – if used make sure the tip is well secured.
- 2) NGK Spark Plug BR8EIX iridium electrode with solid tip.

Long Reach Plugs (uses LR or LRX adapters)

- 1) Denso Spark Plug IKH-27 (stock #5347) has an iridium electrode with a solid terminal tip.

The LRX adapter has an extended hex head to help with some Continental™ engines that have a machined recess around the plug hole. The LRX extension provides socket access if you need to remove the adapter (**not** for tightening the adapter directly) – see below.

IMPORTANT: Remember to **FIRST** install spark plug in the adapter (fully seated and finger tight). **THEN**, insert the combined plug/adapter assembly in the engine and tighten to **18 ft/lb** (standard auto plug torque) through the spark plug **ONLY**. **Do NOT torque the adapter itself**. If you torque the adapters directly, stress will be focused underneath the adapter head and it can fail during installation. Such failures are not covered under warranty. Use anti-seize (sparingly) on the outer/engine side of adapters.

Operators need to monitor spark plug condition and adjust the plug temperature range as needed. The temperature rating is indicated by the NGK “8” or the Denso “27” reference in the part number. If selecting a different range, remember that lower numbers indicate hotter ratings, and higher numbers indicate cooler ratings.

Appendix 2 - deleted this manual

Appendix 3 – Tach Electrical Specifications

- 1) Bus power – circular connector pin A (red) 12, 24, or 48 volt systems
 - a) Minimum - 9 volts
 - b) Maximum - 58 volts
 - c) Current draw from bus:
 - i) less than 0.5 amp (normal operating conditions)
 - ii) less than 1.0 amp (maximum draw with no-op internal alternator)
- 2) Tach – circular connector pin F (blue)

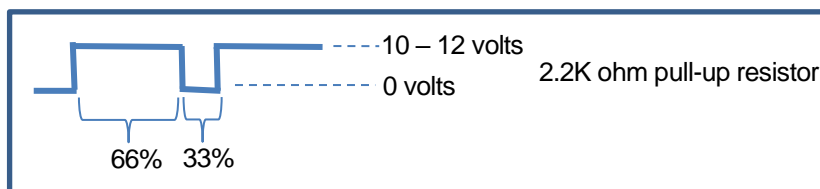

Appendix 4 - Installation Checklist

Installing your E-MAG ignition will require

- 1) Attaching three (four if you use the tach) wire connections from the ignition Control Plug.
- 2) Installing spark plugs, plug adapters, and a trim-to-fit harness.
- 3) Installing a manifold pressure tube connection.
- 4) Blast tube cooling.
- 5) Installing your E-MAG ignition on the engine.
- 6) Locate set-up position references. TC, MIN, and MAX.
- 7) Test, tune, and monitor to ensure proper operation.

What's included

200-6X (Lycoming™ or Continental™ version) ignition set includes:

- 1) 1 ignition module.
- 2) 1 Standard Control Plug connector kit (solder connections w strain relief clamp)
 - a) Circular plug - 6 pin female.
 - b) 2" of 1/8" heat shrink tubing.
 - a) 3" of 3/8" heat shrink tubing.
- 1) MAP connections (1/8" barb fitting, 10-32 female, and 1/8" NPT female):
 - a) 1/8" hose barb can be used with the 1/8" ID tubing provided, or it can be removed to access:
 - i) 10-32 female thread fitting, that can be removed to access:
 - ii) 1/8" NPT female thread in the ignition case.
 - b) 36" silicone MAP tube (1/8"ID x 1/4" OD).
 - c) 3 each, nylon tube clamps for 1/4" OD MAP tube.
- 2) Ignition gasket.
- 3) Piston Stop Tool

Auto Plug Adapter set includes

- 1) 6 auto plug adapters - specify "LR" long-reach, "SR" short-reach, adapters when ordering.
- 2) 6 copper gaskets.

Trim-to-fit harness set includes

- 1) 26' of custom E-MAG low noise plug wire.
- 2) Coil connections:
 - a) 6 coil boots.
 - b) 8 coil terminals (two extras).
- 3) Spark plug connections – a set of straight and 90-degree connectors is included to be used as needed:
 - a) **90-degree** connections
 - i) 6 90-degree plug boots.
 - ii) 8 90-degree plug terminals (two extras)
 - b) **Straight connections**
 - i) 6 straight plug boots
 - ii) 8 straight plug terminals (two extras).
- 4) 1 crimp tool.

Other Optional Parts **specify when ordering**

- 1) Circular control plug with pre-wired pig-tail – 72” wire bundle. Wires are epoxy potted in a shorter connector head (in lieu of Standard Control Plug above). This eliminates soldering wires to the standard connector. We suggest the standard connector kit if you already have imbedded wiring to the ignition(s).
- 2) Mounting Studs – Lycoming™ Shorter (1-5/8”, # 31C-13) studs will be needed to replace the longer ones you will remove along with your old impulse spacers.
- 3) Mounting Clamps – 200-6X have a 0.19” thick flange that requires compatible clamps.
 - a) If replacing thick flange magnetos, such as the 0.31” thick flanges on some Continental™/Bendix styles, your old clamps will not work.
 - b) Some Continental™/Bendix style clamps (#535847) have a shallow reach that will not provide suitable contact surface. **Continental™ clamp #630535 (not stocked by E-MAG) have a longer reach and proper thickness.**
- 4) Mode Switch kit – controls 1 or 2 model 200 ignitions. The mode switch includes two 1K resistors with integrated color-coded wiring. Mode Switch is optional for normally aspirated engines but is REQUIRED for boosted engines.

Installation supplies and tools needed

- 1) Silicone spray – used when fabricating trim-to-fit harness.
- 2) Ohm meter - recommended (but not required) to test spark plug wires after assembly.
- 3) Solder iron and rosin core solder for control wires (not needed if ordering pre-wired Control Plug).

Other hardware and fittings NOT included

- 1) Fittings to attach the manifold pressure plumbing to the engine.
- 2) P-lead switch to control the ignition ON/OFF function (you can re-use an existing switch).
- 3) Fuse or breaker for bus protection and/or power test switch.
- 4) Blast Tube cooling (new or re-use existing).
- 5) Spark Plugs – readily available at auto parts outlets. Recommendations listed later in the manual.
- 6) Spark plug wire supports and wire separators.
- 7) Ignition mounting clamps. You may or may not be able to re-use existing clamps. See discussion elsewhere in the manual.

Appendix 5: Harness Fabrication (leads)

Trim-To-Fit Harness

Lead kits use our custom low-noise, distributed inductance, plug wire that is not shielded. We have no (zero) reports of noise problems from customers using this wire when properly installed and in good condition. If you do hear spark noise, something is not installed or functioning properly. Plug “clicking” noise over the radio is a useful maintenance signal. Something is loose or worn and arcing - which causes radio clicking noise. Leads should be kept separated. Do NOT bundle them together which can cause them to be inductively coupled. Wire looms can be purchased at auto parts stores, but a simple separator can be fabricated out of tie-wraps and 1/4” segments of leftover MAP sensor hose.



Criss-Cross vs. Up-Down

It's relatively immaterial whether you route plug leads in the traditional magneto criss-cross fashion (one ignition wired to alternating upper and lower plugs) or one ignition firing all the upper plugs and the other ignition firing all the lower plugs.

Organizing leads

Because plugs in each Bank fire simultaneously, the coil attachments, within each Bank, are interchangeable. Example: Plug wires for cylinders 1&2 can attach to either coil tower of Bank A. This flexibility can reduce congestion and wiring cross-over at the back of the ignition when attachments favor routing to the left and right sides of the engine.

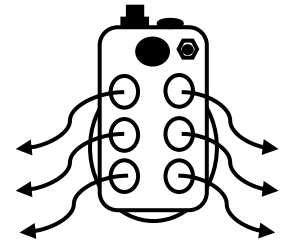

Lead Fabrication - Trimming

The red outer jacket and the white inner layers are separated by a reinforcing fiber weave. The conductive element is a spiral wound wire around a Kevlar core (avoid when trimming). Use a razor blade to trim the OUTERMOST red and fiber layers ONLY 3/4” from the end, all the way around the wire. Avoid cutting anywhere near the center core. The white insulation layer separates easily as you twist the trimmed outer jacket.

Note 1: The center core is easily nicked and weakened by contact with a Stripping tool or a blade. DO NOT use the wire stripping station on the crimp tool.

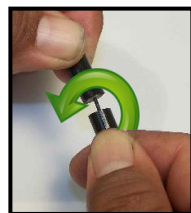
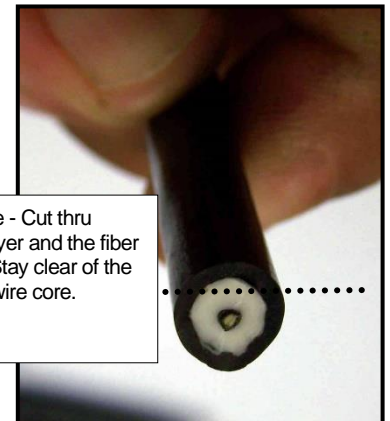

Terminals and Boots

Coil ends - The brass terminals and 90-degree flat-backed boots are for the coil end connections. Run the wire completely through the boot so you have a couple of inches extended past the boot. This will give you room to work the wire and terminal. A light coating of **SILICONE SPRAY** (not included) is required to lubricate the wire as you work it through the boot.

Plug ends – *90-degree boots and terminals are standard, but you can specify straight plug boots and terminals (when placing your order) at no additional cost.* With either style, you can crimp the terminal to the wire and then insert the assembly into the boot with silicone spray lubrication.

Note 1: It is best to push wire into the boot (rather than pulling) to avoid straining the wire core.

Note 2: Free the terminals from their strips with wire cutters. The terminals are NOT finger friendly. They will easily cut if not handled carefully.

Pre-Crimp - Fold the $\frac{3}{4}$ "

of exposed wire core back against the lead and position it in the crook between the terminal ears. Then finger pinch the terminal ears to 1) provide a preliminary snug fit, and 2) reduce the spread between the ears so they fit in the "W Crimp"

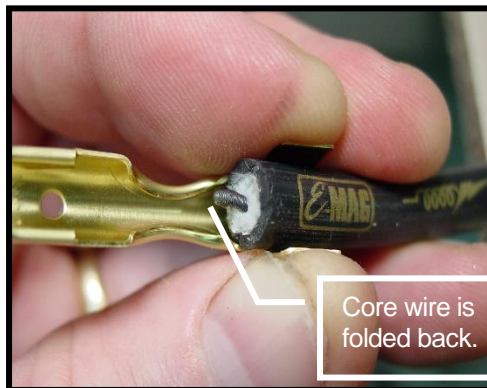

station of the crimping tool. Position so you have at least $\frac{1}{8}$ " of plug wire past the terminal ears.

Final Crimp - Crimp the terminal using the W Crimp Station on the Tool. Position the ears so they feed toward the side with the "W" point. The ears will roll back toward each other and imbed themselves in the outer jacket as the Final Crimp is formed. Push (not pull) the terminal to final position inside the boot.

Coil terminals will need to be bent 90 degrees (at the narrow section) before positioning in the boot.

Resistance Check - Verify the finished leads are assembled correctly with a simple ohm check. Each lead should produce roughly 180 ohms of resistance per foot of plug wire. To check, disconnect the leads at both ends so you can make (firm) ohmmeter contact with the terminals on each end. Watch the ohmmeter display while you exercise each end vigorously (twist/bend/tug) to see if the reading jumps significantly (several times the normal range). To repair a crimped terminal end, simply snip off the bad end (assuming you have an inch or so to spare) and replace with a new terminal.

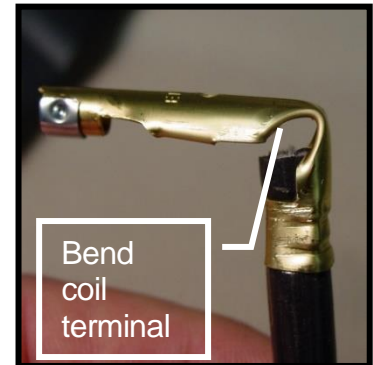

Note 1: Resistance checks are also recommended at annual inspection. It tests the condition of the conductive components, but it does not check the electrical insulation, which is another way that wires can fail. A visual inspection of plug wire is recommended, especially in areas of possible

chafing.

Harness Terminations

The terminals on both ends of the plug wire are secured by a spring steel outer band with a detent. Verify that you feel and/or hear the steel band detent **snap-lock** as the terminal slips over the connecting post:

- 1) **Coil Terminals** - The coil terminal post inside the tower has 3 grooves. As you push the circular terminal onto the post, you will feel and/or hear a series of sharp clicks as the terminal detent snaps over these grooves.
- 2) **Plug Terminals:** Spark plugs have an hourglass shaped cap. You will feel and/or hear a sharp click as the terminal snaps over the plug cap.

In either case, **if you don't feel and/or hear the terminal snap**, remove and inspect for irregularities or damage. If needed, replacement terminals can be provided by E-MAG. **If not properly secured the leads can come lose, which risks interrupting ignition operation, and can damage the ignition coil. NEVER operate the ignition (fire plugs) without ALL high voltage loops (coil to wires to plugs to engine to plug to wire to coil) secured in place.**

Note 1: After plug wires are connected, verify the boot sleeve is fully inserted over the spark plug and coil towers and is relaxed, i.e. not "compressed" such that it's left pushing the boot away from the terminal.

Note 2: When removing the wires from either end, pull the boot/terminal straight off the post. If you use the 90-degree boot to lever/pry/bend the terminal off the post, you can distort and weaken the terminal spring retention clip.

Note 3: If using strap (Adel) clamps to secure plug leads, make sure the clamps are properly sized. Clamps for smaller size (previous) wire may be too tight and can crush/compromise the internal silicone insulation of our 8mm wire.