



Product Documentation

Series P114

Installation and Operating Guide

Instruction for most Lycoming™ and
Continental™ Styled 4-Cylinder
EXPERIMENTAL Engines



Lycoming™ Style
4-Cylinder
P114-L4

Continental™
Style O-200
P114-C4



Changes to Manual: Changes, corrections, and supplements may be made at any time (see version number on cover page – bottom right). Refer to E-MAG’s web page “Downloads” for the most recent version.

Alerts and Service Notes: Prior to installation and operation, review all applicable Alerts and Service Notes affecting your equipment. See E-MAG web site <https://emagair.com/service-notes/>.

Experimental Aircraft Only: Series 114 ignitions are not certified and are not approved for installation on certificated aircraft. They may be suitable for ASTM approved installations.

Warranty: E-MAG electronic ignitions are warranted for one (1) year from the date of purchase. E-MAG will repair or replace ignition modules within the warranty period that, in E-MAG’s sole opinion, have not been subjected to abuse or attempted field repairs. This warranty is limited to the purchase price of E-MAG hardware and does not cover the engine or other engine components that may be affected by defects or failure of the system. Do not attempt to open or separate the ignition case sections. Doing so will void your ignition warranty.

CAUTION: The aircraft operator has the SOLE responsibility of determining how to appropriately and safely configure and control engine and ignition operation. Nothing stated by E-MAG in this manual, its employees, owners, agents, representatives, or affiliates should be construed as overriding or invalidating the engine manufacturer’s instructions. E-MAG has NOT performed testing on the wide variety of engines in popular use and cannot offer specific advice as to proper/suitable ignition configuration.

Notwithstanding engine manufacturer approval of certain engines to burn auto/alternative fuels, such endorsements almost certainly presume operation with fixed magneto timing – and not variable firing electronic ignition. Operators are SOLELY RESPONSIBILITY for independently verifying proper engine behavior with standard and/or alternative fuels including the ignition setup AS CONFIGURED BY THE OPERATOR.

Markings: Data label will contain Model No., Serial No., and Version Log numbers (“VL”XXYYZZ). VL code:

- First two characters (XX) are the board version number.
- Second two characters (YY) are the firmware version number.
- Last two characters (ZZ) are for internal tracking.

If the unit has been changed or updated by E-MAG, a service sticker to the right of the silver data label will show updated board and firmware numbers.

USING THIS MANUAL.....	3
TIMING SHORT-CUT ABBREVIATED OVERVIEW.....	4
INSTALLATION AND OPERATION.....	4
COCKPIT CONTROLS.....	4
CONTROL PLUG WIRING.....	5
LED SIGNALS	6
IGNITION ATTACHMENT.....	7
PLUG WIRES – CYLINDER ASSIGNMENTS	8
AUTO PLUGS AND ADAPTERS	8
MANIFOLD PRESSURE (MAP)	9
INSTALL AND SET IGNITION TIMING.....	10
PULL -THRU TEST	13
OPERATING NOTES	14
MAINTENANCE.....	16
WIRING DIAGRAM.....	17
APPENDIX 1: SPARK PLUGS & ADAPTERS.....	19
APPENDIX 2 : TACH SPECS	20
APPENDIX 3: INSTALLATION CHECKLIST	21
APPENDIX 4 : LEAD FABRICATION	22
APPENDIX 6: COM PORT.....	25
APPENDIX 7: LEFT/RIGHT TESTING.....	26
APPENDIX 8: DRIVE GEARS	28

Using This Manual

This manual will include supplemental notes, comments, and tips that will appear as *blue* text.

Lycoming™ is a registered trademark of Avco Corporation.

Continental™ is a registered trademark of Continental Aerospace Technologies™.

Certain segments of this manual are specific to the Continental™ (O-200) or the Lycoming™ ignition versions. Those segments will be identified with the bracketed or colored notation “[Continental™]” or “[Lycoming™]” as appropriate. The “Lycoming™” reference applies to Lycoming™ as well as other Lycoming styled engines.

*This manual is largely applicable to **Series 113** ignitions, except those earlier units:*

- 1. Were rated for 12-volt bus connection only.*
- 2. Did not have the same 4-degree starting lag feature.*

Note: Over time many older units have been upgraded to newer V17 or V18 circuit boards, that will include Series 114 functionality. See Service Sticker markings.

Exercise care when handling the ignitions, engine, or propeller. There is a significant risk of burn, electrical shock, injury, or even death. This manual may offer safety suggestions, but it is NOT to be considered a complete list of the potential hazards, NOR is it presented as a complete set of safety precautions that should be followed.

Risk of equipment damage: *IMPORTANT***** Firing the ignition without all high voltage loops in place, risks damaging the coils and/or electrical shock to the handler. If incurred, such damage may not be immediately evident. High voltage loops include the circuit from a given coil tower, to plug wire, to plug, to engine block, to companion plug, to companion plug wire, to companion coil tower. Each pair of cylinders (1&2, 3&4) constitutes a separate high voltage loop.

ID	Date	Summary of Principal Changes
LC114V31	02/23/20	Added more illustrations to better demonstrate installation.
LC 114.32	05/25/23	Major reformat to match other E-MAG manuals. Numerous changes and additions.
LC 114.33	12/20/23	Revised (500 hr vs. annual) inspection guidelines.

Timing Short-Cut Abbreviated Overview.

New installers should review the entire manual. To set timing, installers will select A) jumper IN or jumper OUT (between control plug terminals #2 and #3), and B) a parked engine position at TC or a position 1 to 6-degrees **after** TC (your “TC Offset”). *see Timing Tools.*

- 1) **Mount Ignition:** Insert the ignition(s) at any convenient orientation and tighten mounting clamps to 17 ft/lb. Verify bus power and kill switches are both OFF, then connect the Control Plug *see Note 1.*
- 2) **Pre-position engine/prop** to your chosen TC Offset position. *see Note 4*
- 3) With ignition kill switch OFF, **turn bus power ON.** *The LED(s) will light RED:*
- 4) **Pressure pulse** (first time) the manifold pressure tube to 0.5 PSI for 1 second continuous. *LED(s) will start blinking RED. see Note 2*
- 5) **Pressure pulse** (second time) the MAP tube, and the *LED(s) will start blinking GREEN.* Timing is complete.
- 6) **Turn bus power OFF and then back ON.** Steady GREEN LED(s) verifies the Clock position was stored and retrieved from memory after power up. *see Note 3*
- 7) Basic setup is complete. Repeat for second E-MAG.

Note 1 Verify Jumper wire selection (between #2 & #3) before connecting plug. See Timing Tools

Note 2: Pressure pulses can be done by blowing into the MAP tubes one at a time, or you can time simultaneously if MAP tubes are tied together. Alternatively, you can pinch/fold the tube a couple of inches from where it connects to the ignition, creating a trapped air chamber. Squeezing this chamber will create the needed pressure pulse.

Note 3: Occasionally the LED will be shimmering GREEN/RED/YELLOW which means the engine is sitting on the boundary edge between the GREEN and RED zones. The timing routine was successful. Nudging the prop will turn the LED steady RED or GREEN as normal.

Note 4: E-MAGs use TC (top center) as a reference for setting timing. TC Offset refers to the static engine position shift (1 to 6-degrees) AFTER TC, that (in conjunction with the Jumper selection) determines the ignition variable firing range.

Installation and Operation

Cockpit Controls

- 1) Circuit breaker or fuse (one per ignition).
- 2) Ignition kill switch (p-lead) can be either:
 - a) Rotary switch OFF/R/L/Both/Start.
 - b) Toggle switch up/ON and down/OFF.
- 3) Ignition power test switch (*Note 1*) is for testing ignition internal alternator – *see Ignition Checks:*

- a) Ramp Checks - a basic ignition and internal alternator check.
- a) Cut-Out test – a stress test for ignition, internal alternator, and the overall system to find the low-speed operating boundary. Should be done after installation, annual check, and after major maintenance.

Note 1: The power test circuits can be configured several ways and is largely a matter of builder preference. That said, the two controls involved (kill switch and power test switch) can be located next to each other on the panel, making these tests one-handed, intuitive, and more ergonomic. Examples using a momentary push-button are shown after the Wiring Diagram.

*NOTE 2: Standard ignition rotation is counterclockwise (as viewed with the ignition shaft pointing at your face). If your ignition rotation is different, the ignition can be re-programmed for reverse rotation at the factory (only). If reverse rotation is needed, make sure to specify *reverse rotation* when ordering, **and** when returning for factory service.*

Control Plug Wiring

- 1) The removable Control Plug has six wire positions that are secured by a screw cage-clamp for each wire. The Control Plug is secured to the ignition by self-capturing anchor screws, one on each end of the Control Plug.
- 2) Pinouts are marked on ignition case.
 - a) **Terminal #1 “G”** connects to a nearby engine case ground. *You cannot rely on the ignition’s mechanical attachment to the engine to provide a stable ground connection.*
 - b) **Terminal #2 “Rx”** may be used for jumper connection to #3.
 - c) **Terminal #3 “Tx”** may be used for jumper connection to #2.
 - d) **Terminal #4 “K”** connects to your cockpit kill switch (p-lead). To turn ignition OFF, ground the p-lead with the kill switch. To turn ignition ON, un-ground the p-lead with the kill switch.
 - e) **Terminal #5 “B”** connects to your 14 or 28-volt aircraft bus (*see Note 7 and 8*). Route through a power test switch and suitable circuit protection. Possibilities are:
 - i) A 3 to 5-amp fuse and separate power test switch.
 - ii) A 3 to 5-amp switchable circuit breaker, which can satisfy circuit protection and power test duties.
 - f) **Terminal #6 “T”** is a courtesy (optional) connection to provide a digital tach signal.
 - i) Default tach is 12-volts, 2 pulses per revolution – *see Note 6*.
 - (1) Pulse count can be configured for 1 pulse per rev:
 - (a) By E-MAG - specify when ordering.
 - (b) At the tach instrument itself (easiest) - see your tach instrument documentation.
 - (c) Using a downloadable program from E-MAG – not recommended as this requires considerable “fiddling” (com cable fabrication, USB to serial hardware and drivers, etc.).
 - (2) Tach voltage can be reduced to 5-volt by installing the included Zener diode. See wiring diagram.



Note 1: **CAUTION!** Shower or vibrator type starting aids are **not compatible** and will damage your E-MAG – remove before installation.

Note 2: E-MAG kill (p-lead) wire does not make radio noise and does not require shielding. If replacing a magneto, your existing shielded p-lead wire can be re-used. If doing so, the outer shield needs to be trimmed clean and kept well clear of all other terminations.

Note 3: All E-MAGs are “starting ignitions”. In a dual installation, or if replacing a non-starting magneto, revise your starting procedures, and/or remove any key switch starting blocks (remove the jumper on the back of the key switch) to your E-MAGs.

Note 4: Whenever the aircraft bus is powered ON, the ignition is “awake”. It draws a small amount of current (approx. 40 milliamps) even when not firing plugs. Use the master bus switch (or breakers if necessary) to power down the ignitions when not in use.

Note 5: Do not power the ignition ON when you have a ground battery charger connected to the bus. Pulling the breaker will isolate the ignition when charging.

Note 6: Collect your tach signal from only one ignition unless your instrument has provisions for two (separate) tach inputs. Unlike a magneto, E-MAGs produce a tach signal even when kill switch is turned to OFF. E-MAG’s tach output is a courtesy feature that is unrelated to the ignition’s primary purpose. Due to the variety of instrument options available, our ability to support and troubleshoot tach interface issues is limited. The ignition default signal is 12-volt, 2 pulses per revolution. This can be changed to 5-volt (if needed) by installing the diode included in the separate incidental pack.

Note 7: Series 114 ignitions can operate on 12, 24, or 48-volt bus. **Series 113 with circuit boards (version 16 or before) are rated for 12-volt only.**

Note 8: Long power cable runs to a remote main battery (canards, amphib, others) may need to route ignition bus power through a dedicated 16 AWG cable connected directly to the battery. This will avoid sharing a long power cable with the starter motor, a combination that can exaggerate power dips during startup and inhibit ignition operation when cranking. Old or weak battery, tired starter, smaller main bus cables, corroded terminals, can all degrade bus power and can have a similar affect. There is some indication that light weight lithium batters can also aggravate bus power starting dips.

LED Signals

- 1) **DARK LED Caution:** When ignition is powered ON and kill switch (p-lead) is ON the unit is capable of firing plugs (“HOT”). When powered ON/HOT the **LED will be dark/OFF**. Seeing a lit LED (red or green) is an affirmative verification you are in Setup mode, where the ignition will not fire plugs.

- 2) Setup Mode colors: Enter Setup Mode by powering ignition ON **while** the kill switch (p-lead) is OFF/grounded. Setup LED colors are:
 - a) **RED in all ignition shaft positions, except the spot where the ignition is timed.**
 - b) **GREEN when ignition shaft is sitting at the stored timing target.**
- 3) Maintenance alerts and boundary LED colors.
 - a) Yellow alert – The ignition has one moving wear part – the shaft. If axial movement (wear) is detected, the ignition can send a “range-check” alert by turning the LED yellow. If detected at power up (i.e. on the ground prior to flight) the ignition will A) turn the LED to pulsing yellow, and B) lock the ignition (no-op at ramp check) as a means of forcing the operator to investigate. If the range-check alert later clears, the ignition will resume normal operation. A range-check alert will not stop operation after it passes the initial powerup check. The pulsing yellow range-check lock is a **safety fallback**. Routine inspection and maintenance should identify and **address wear issues beforehand**. Staying current with maintenance (outline later in manual) is far more convenient.
 - b) Boundaries – The ignition tracks 1024 unique rotational position addresses. If the ignition is parked on the boundary edge between two addresses, it can teeter (electronically) back and forth. This can be distracting when operators look for steady GREEN after timing or when checking timing. Sitting on a timing boundary, the LED will be a dull shimmering red/green/yellow color, instead of the expected steady GREEN. Nudge the prop either way to move off the boundary and get a steady RED or GREEN.

Ignition Attachment

[Lycoming] A magneto mounted on the right side is (typically but not always) a non-impulse style magneto - where the studs and magneto drive gear can be re-used with your E-MAG. A magneto mounted on the left side is (typically but not always) an impulse style magneto and can be identified by the spacer located between the magneto and the accessory case (see photo). Before installing an E-MAG, this spacer needs to be removed and the long spacer studs need to be replaced with shorter studs (#31C12). The drive gear for an impulse magneto will not cross over to your E-MAG, so you will need to source a non-impulse drive gear (#68C19622). See Appendix 8 for detailed description of drive gears.

Tip: Penetrating oil and heating the case area (heat-gun) will make stud removal much easier.

Note: Common Slick/Champion style hold down clamps (K3784) will work with the E-MAG 0.19” thick flange. Clamps designed for thicker flanges or ones with shallower reach will not work.



Plug Wires – Cylinder Assignments

As with any wasted-spark ignition, E-MAGs fire spark plugs in pairs. Cylinders 1&2 and 3&4 are paired with plug wires connected to each end of a double ended coil “bank”. Coil banks are separated by a molded bar with an E-MAG routing label between each bank. *Attachment points within a bank are interchangeable. Example: Cylinder 1 could connect to either tower. Cylinder 2 will connect to the other tower. See routing label and note the red dots that identify the correct cylinders.*



[Lycoming™] Cylinders 1 & 2 (cylinders nearest prop)
[Continental™] Cylinders 1 & 2 (cylinders furthest from prop)

[Lycoming™] Cylinders 3 & 4 (cylinders furthest from prop).
[Continental™] Cylinders 3 & 4 (cylinders closest to prop).

*Note 1: The Pull-Thru test (described later) is the best way to verify your installation follows correct (cylinder pair) firing order. This test uses encoder data at the lowest possible resolution – i.e. **pull-thru firing position cannot be used to check tracking precision.***

Note 2: If using strap (Adel) clamps to secure plug leads, make sure the clamps are properly sized. Reusing clamps for smaller (previous 7mm aviation leads) wire may be too tight and crush/compromise the internal silicone insulation layer of our 8mm leads.

Note 3: Criss-Cross vs. Up-Down - It's relatively immaterial whether you route plug leads in the traditional magneto criss-cross fashion (one ignition wired to alternating upper and lower plugs) or one ignition firing all the upper plugs and the other ignition firing all the lower plugs.

Auto Plugs and Adapters

Aircraft cylinders are typically tapped for 18mm spark plug threads. To use 14mm automotive style plugs, E-MAG can provide auto plug adapters. There are numerous auto spark plug styles and temperature ranges available. E-MAG has NOT studied the relative durability or performance of different plug brands and styles. Customers need to monitor plug condition and evaluate and adjust as necessary. The plugs



SR LR LRX

listed in Appendix 1 have a history of good service. Set plug gaps at 0.030" to 0.035".

Long Reach (LR) vs. Short Reach (SR) Cylinders

Cylinders are made with two different spark plug thread depths. Match spark plugs and plug adapters (LR or SR) to your cylinder depth when ordering. LR and SR cylinders can be identified:



- 1) By the replacement spark plug catalog call-out for your engine. If the call-out has the letter "M" - as in REMXXX, you will need SR plugs and adapters. If it has the letter "B" as in REBXXX, you will need LR plugs and adapters.
- 2) By looking for the "M" or "B" markings on the side of your old aircraft plugs (assuming you had the correct plugs).
- 3) Cylinder thread depth can also be measured directly.
 - a) Short Reach ("SR") adapters have external thread length of approx. 1/2".
 - b) Long Reach ("LR") adapters have external thread length of approx. 3/4"

LRX adapters are for certain 6-cylinder engines – not applicable.

Spark Plugs - See Appendix 1 for specific spark plug recommendations.

IMPORTANT: *Remember to FIRST install each spark plug in the adapter (fully seated and finger tight). THEN, insert the combined plug/adapter assembly in the engine and tighten to 18 ft/lb (standard auto plug torque) through the spark plug ONLY. Do NOT torque the adapter itself. If you torque the adapters directly, stress will be focused underneath the adapter head, and it can fail during installation - not covered under warranty. Use anti-seize (sparingly) on the outer/engine side of adapters. Auto plug manufacturers do not recommend anti-seize on their plugs.*

Manifold Pressure (MAP)

The ignition comes with 3' of 1/8"x1/4" silicone MAP tubing. A 1/8" barbed nipple is located on the back of the ignition next to the LED. Tubing connected to the nipple is secured using the included nylon ratchet clamp - tighten gently. Your incidental kit includes a pulse dampener (blue double ended barb) that will install in the MAP tubing close to where you source manifold pressure. The dampener has an arrow indicator that should be pointing toward the ignition. If installing two E-MAGs, a single dampener in the common line before you tee to left and right will serve both sides. If you have a manifold pressure gauge, tie into the existing line as your pressure source.



With **normally aspirated** engines, the MAP tube is a fail-safe input. Meaning if the MAP plumbing fails the ignition will automatically retard to a flyable, but slightly less efficient, firing position.

With **turbo normalized or boosted** engines, MAP plumbing is **NOT** considered fail-safe. A MAP plumbing failure can, in certain conditions, call for more ignition advance than is appropriate or safe.

Excess advance can result in loss of power, overheating, and/or damage to the engine. For this reason:

- 1) The MAP plumbing for two ignitions should be kept separate so a plumbing failure on one side would affect only one - not both ignitions.
- 2) In the event of a MAP plumbing failure the ignition on that side can be isolated (turned off). The other ignition will be unaffected.

[Lycoming] All Lycoming™ cylinders have a primer port that can be used to access manifold pressure. An 1/8" NPT fitting with 3 or more inches of metal primer tubing (not included in your kit) will provide a heat barrier before transitioning to the MAP tubing provided.

Install and Set Ignition Timing

Install ignition drive gear(s) prior to insertion – see Appendix 8. *E-MAGs use RPM and MAP pressure to automatically adjust the firing angle over a variety of operating conditions. The bottom of the variable range is for high-power (high manifold pressure) conditions at take-off and climb (less advance). The top of the variable range is for low-power (low manifold pressure) conditions in cruise (more advance). The default spread between power and cruise firing is 9-degrees.*

Installers will use two simple tools to set ignition timing so the high-power end of the variable range matches the engine data-plate recommendation. (*see Timing Tools below*).

- 1) **Mount Ignition:** Verify bus power and kill switches are **both OFF**. Insert the ignition (with gasket) and secure mounting clamps finger tight. Rotate the ignition to any convenient orientation and then alternately tighten mounting clamp nuts to 17 ft/lb.
- 2) **Pre-position engine/prop** to the appropriate TC Offset position (*see Note 3 and Timing Tools*).
 - a. **Lycoming™ engines will use flywheel TC mark as your TC Offset reference.**
 - b. **Continental™ engines might use prop flange markings (harder to be accurate), or the manufacturer's piston stop to find your TC Offset reference.**
- 3) **Enter Set-up Mode:** Connect the Control Plug and turn bus power ON (kill switch remains OFF). In Setup Mode, the LED will light either:
 - a. Steady RED when the engine is **not** sitting at the currently stored TC Offset position.
 - b. Steady GREEN when the engine **is** sitting at the currently stored TC Offset position.
- 4) Sitting at your intended TC Offset position and with steady RED LED showing:
 - a. ***Pressure pulse** (first time) the MAP tube to 0.5 PSI for 1 second continuous. Steady RED will start blinking RED.
 - b. ***Pressure pulse** (second time) the MAP tube, and *blinking RED will start blinking GREEN. Timing is now set.*

**Pressure pulse can be done by blowing into the MAP tubes one at a time, or you can time left and right ignitions simultaneously if MAP tubes are tied together. Alternatively, you can pinch/fold the tube a couple of inches from the ignition, creating a trapped air chamber that you can squeeze to achieve the needed pressure pulse.*

- 5) **Confirm Timing** (TC Offset and Jumper): Turn bus power OFF and then back ON.
- Steady GREEN LED verifies the TC Offset position was stored. [see Note 4](#)
 - Also confirm you have the correct Jumper (IN/OUT) setting. [see Timing Tools](#)

*Note 1: Make sure Kill switch stays OFF until all high-voltage connections (plugs, plug-wires, coil) are in place. Firing plugs without all high-voltage connections risks damaging the coil. **No Timing procedure requires ignition to be HOT.***

Note 2: Don't time ignitions on top of a GREEN LED TC Offset position. The ignition is already timed for that location.

Note 3: Pre-position engine to your TC Offset position before powering ON. The ignition will abort the timing routine (after your first MAP pressure pulse) if the engine is moved after entering Setup Mode (FW V40 and after). If you happen to be sitting on the boundary edge between two adjacent addresses, the ignition can (internally) teeter back and forth. This will be seen as movement and abort the timing routine. Nudge the prop "very" slightly, either direction, to move the ignition off the boundary. Related condition described in Note 4 below.

Note 4: Occasionally the LED will be shimmering GREEN/RED/YELLOW when the ignition is sitting on the boundary edge between the GREEN and RED zones. The timing routine was successful. Nudging the prop either way will turn the LED steady RED or GREEN as normal.

Timing Tools - set the variable range:

Installers will use two simple built-in tools to set the high-power (less advance) end of the variable firing range to match the engine manufacturers (data plate) recommended timing.

- Jumper (IN/OUT)** – Refers to a short jumper wire between terminals #2 and #3 of the control plug. Jumper IN reduces the advance range by 4.2-degrees (from factory default configuration).
- TC Offset** – Refers to the parked engine/flywheel position - either:
 - TC (zero TC Offset)
 - Anywhere from 1 to 6-degrees **after** TC - will further retard timing. [see Note 4](#)

Examples

25-Degree data plate engines (typical of Lyc 320, 360) could start with 1) Jumper IN and 2) TC Offset position at TC. High-power firing will be roughly 25-degrees. Cruise firing will be roughly 34-degrees.

20-Degree data plate engines (typical of Lyc 390) could start with 1) Jumper IN, and 2) TC Offset at 4 to 5-degrees **after** TC. High-power firing will be roughly 20-degrees. Cruise firing will be roughly 29-degrees.

27-Degree data plate engines (typical of some but not all Continental engines) could start with 1) Jumper OUT, and 2) TC Offset at 1-degree **after** TC. High-power firing will be roughly 27-degrees. Cruise firing will be roughly 36-degrees.

25-Degree (Alternate) data plate engines could be set 1) Jumper OUT and 2) TC Offset at 4 to 5-degrees after TC. This is operationally equivalent to the earlier example (25 to 34-degrees variable

range). This alternate is useful if you later want/need to explore (**cautiously**) more aggressive advance settings, where you'd then use a TC Offset target closer to TC.

Other settings (18, 22, 28, etc. degree engines). Intermediate settings can be achieved by different Jumper and/or interpolated TC Offset positions. Start with the closes example above and shift TC Offset position as needed.

Operational Timing Check.

A quick temperature check, at sustained full power, can confirm your initial setting or suggest further adjustment may be needed. Most operators aim for peak CHTs in the range of 385 to 395 degrees - see Note 2 below and your engine manufacturer's temperature guideline. If CHTs are elevated, reducing the ignition timing slightly should help. *See Note 2 and Appendix 7*

*Note 1: Old habits are hard to break. The timing reference for E-MAG is the TC mark - **not** the 20 to 25-degree marks used when timing magnetos.*

Note 2: Lowering ignition timing slightly (less advance) to achieve your target temperature is a conservative timing adjustment. Increasing ignition timing (more advance) should be done cautiously - if at all. Overly aggressive timing can damage the engine. Operators need to be mindful of the limitations of CHT readings. Ignition timing is a significant, but not the only, factor influencing CHTs. Baffling, mixture, prop, cylinder design, cylinder break-in, air temperature, air density, humidity, fuel type, induction boost, and more can all affect the indicated CHT. Every installation should be considered unique – assume nothing.

*The goal in setting/adjusting ignition timing is **not** to deploy the maximum amount of ignition advance possible. Rather, we're looking for the **least** aggressive setting that maximizes efficiency - **and no more.***

Note 3: "Checking" ignition timing is easy and should not be confused with re-timing. To check timing, simply pre-position the engine near your TC Offset position and power ignition ON (p-lead OFF). Move prop back and forth slowly to reacquire the GREEN LED. Compare GREEN LED position with your TC Offset target. If you are within a degree, you are good (no need to re-time). When you re-time, you will override (erase) the previous setting – information you need to capture and document if timing has, in fact, moved.

Note 4: Lycoming™ engines have a TC mark on the PROP SIDE of the flywheel that will align with a reference hole in the starter motor case. They also have a TC mark on the ENGINE SIDE of the flywheel that will align with the upper engine case seam. Either reference can be used.

*Tip: Which side is "after"? Positions **after** TC can be found by starting with engine parked at TC, then move the prop in normal direction to your TC Offset target 1 to 6-degrees.*

*Tip: On a 149-tooth ring gear each tooth represents 2.4 degrees. $(360/149=2.42)$ Count teeth on **your** ring gear to verify.*

Note 5: Startup Firing Lag:

E-MAGs with firmware V40 (and after) have an automatic 4 degree starting lag to make certain start firing occurs well after TC. Prior to firmware V40, start firing occurs where the ignition is timed.

Units with older firmware can get the same starting lag effect by timing with the “25-Degree (Alternate)” in the timing examples above (assuming you have a 25-degree engine).

*Note 6: Communication port (remote control) is **not** required to setup, tune, and fully enjoy your ignition. See Appendix 6.*

Blast Tube Cooling

E-MAGs are designed for a high-heat environment, but there are still thermal limitations and benefits to keeping the equipment as cool as possible. Blast tube cooling is a simple way to reduce operating temperatures, and we consider them mandatory. Blast tubes should be directed at the round neck, immediately behind the mounting flange. The mere presence of blast tubes does not guarantee they are effective. After initial operations, operators can verify the ignitions are operating within temperature guidelines (under 200F during flight). A thermal reactive label is installed on the electronics case. Alternatively, a thermal probe can verify ignition case temperatures at the forward section of the electronics (box shaped) compartment. Heat-soaking after engine shut down is when thermal labels are likely to record the highest temperature, so be prepared for a high temp bias as you monitor thermal labels. Label that turn dark grey or solid black are signaling a notable overtemp event.



Electrical System Condition

E-MAG’s power dip protection helps guard against brief voltage drops that occur when the starter motor is engaged. In the event of a compromised electrical system (low battery, long cable runs, undersized cable, corroded terminals, cold engine, etc.) bus voltage may not rebound as the starter speeds up (as is normal). A properly designed and functioning electrical system is essential for the ignition to start properly. If bus voltage drops below a certain level while cranking, a safety circuit may prohibit the ignition from firing. The starter motor pulls the largest load on the electrical bus. Keeping non-essential loads turned OFF while cranking will help.

*Note 1: We have no definitive guidance, but there is some indication light-weight lithium batteries **may** contribute to greater ignition voltage dips during startup.*

Note 2: Longer cable runs to a remote main battery may need to access bus power through a dedicated 16 AWG cable connected directly to the battery. This will avoid sharing a long power cable with the starter motor, a combination that can exaggerate power dips during startup and inhibit ignition operation when cranking. Old or weak battery, tired starter, smaller main bus cables, corroded terminals, can all degrade bus power and can have a similar affect. There is some indication that light weight lithium batters can also aggravate bus power starting dips. This measure is seldom needed.

Pull -Thru Test

The Pull-Thru test will confirm 1) plug wire assignments and 2) basic operation of firing circuits:

1. Remove all spark plugs from the engine and reconnect them to the plug leads.
2. ***IMPORTANT*** Rest each plug on the engine case or convenient location such that the metal jacket of each plug is grounded to the engine block. *Alternatively, the plug metal jackets can be wired to the engine block or plugs can be bundled directly to each other with metal jackets in direct contact of each other.*
3. One ignition at a time: Turn bus power ON, Kill Switch ON. Rotate the prop by hand in the normal direction of travel and confirm all plug pairs fire in proper sequence. Any deviation indicates a wiring or setup error.
 - Both plugs for cylinders 1&2 fire roughly 4-degrees after you TC Offset timing position.
 - Both plugs for cylinders 3&4 fire roughly 180-degrees later

Note 1: Multi-Strike. At cranking speeds, the ignition uses a (5) rapid strike sequence for each bank. This means the Pull-Thru Test will not produce the familiar single spark “click”. Instead, you’ll hear the plugs “buzz” - the sound of a multi-strike sequence.

Note 2: Pull-Thru firing positions cannot be used to verify ignition tracking accuracy. It only confirms proper wiring and circuit assignments.

Operating Notes

Engine Management

The high energy spark and variable firing of an electronic ignition will change engine behavior.

Starting

- 1) Wasted spark ignitions (E-MAG and others) fire spark plugs in pairs. On any given cycle only one cylinder, within the pair, is in the compressed “firing” position. At that same time, the companion cylinder is between the intake and exhaust strokes with both valves open. If sufficient vapor is present in the companion cylinder (due to excess priming, throttle, mixture, or any other reason) it can ignite. This is called a “wasted side firing” and will send a pressure pulse down the intake and exhaust pipes. It’s easily mistaken as a backfire or a kick-back, which is different. Wasted side firing is remedied by adjusting your starting procedure to reduce excess fuel.
- 2) To reduce the risk of flooding and wasted side firing, we recommend you begin your search for optimal start-up settings on the extreme lean side and gradually modify (increase throttle or mixture) as necessary to achieve quick and consistent starts.

Lean-limit and mixture control

The familiar lean-rough boundary experienced with magnetos will shift (far leaner) or it may disappear entirely. This precludes the lean-rough boundary as a seat-of-your-pants mixture control (lean to rough - then richen). You will need to lean by your gauges.

Ignition Checks

Your ignition checklist will be extended to include two different ignition alternator checks. The first check will blend easily into your regular left/right Ramp Check routine. The other (Cut-Out test) will be done less frequently. *See power test switch and wiring diagram later in manual.*

1) **Ramp Checks** (roughly 1700 RPM).

- a) Internal Alternator - E-MAG internal alternator operates in parallel with power supplied by the aircraft bus. The ignition automatically transitions between aircraft power and internal alternator power as needed. Aircraft power is required for starting and low idle speeds.
 - i) Running on one ignition only, turn ignition power test switch OFF for 2-3 seconds and back ON. The engine should run smooth during the momentary bus power outage, verifying the internal alternator is working.
 - ii) Repeat with the other ignition.
 - iii) The left/right Ramp Check rpm drops may be quite a bit different with E-MAGs than magnetos. We don't apply the same rules to gauge ignition health.

Any rough or degraded behavior (before, during, or after each side's Ramp Check) indicates a problem - not suitable for flight.

- 2) The **Cut-Out Test** (ground run) should be done after initial installation, power plant maintenance, and at annual inspection. It checks ignition condition, and the entire engine system, in challenging conditions. Internal alternator output will drop at low engine speeds. Forcing the ignition to its low-speed low-power limit demonstrates the system's capacity to operate below your in-flight idle – typically 1000 to 1100 rpm.

Cut-Out Test

- a) Operating on one ignition, lower engine speed to 1200 rpm. Then turn bus power OFF to that ignition. A slight rpm dip may be expected due to the lowered spark energy.
- b) Very slowly lower the engine rpm until the engine reaches low idle limit or quits. A log-book entry will help you track Cut-Out trends over time.
- c) Repeat Cut-Out test on the other ignition, and then with both ignitions.

Note 1: The Cut-Out test marks the low-speed boundary of the entire system (not just the ignition) when the ignition is self-powered. Spark energy is a significant, but not the only factor affecting cut-out speeds. Mis-adjusted idle mixture fowled or partially fowled plugs, induction leaks, mis-adjusted prop, and other factors can affect (elevate) cut-out speeds. Keep this in mind if ever investigating the cause of elevated cut-out speeds. E-MAG bench tests every ignition to verify they will self-power, open air spark, down to 700 rpm. This is well below most in-flight idle speeds.

Note 2: When performing a Cut-Out test and the engine falters, let it to come to a stop and fully power down. Re-applying bus power or activating the other ignition at the last moment to keep the engine running may not restore full operation, and is unlike the power boundary event we are probing.

Maintenance

Condition Inspection (annual – unless otherwise noted)

- 1) **Web Site:** Check E-MAG web site for the most recent Manual (www.emagair.com/downloads), Service Notes (www.emagair.com/service-notes), to verify equipment is current with all updates.
- 2) **Ignition Timing:** Check ignition timing (not re-time). Pre-position the engine near your TC Offset position and power ignition ON (p-lead OFF). Move prop back and forth slowly to reacquire the GREEN LED. Compare GREEN LED position with your TC Offset target. If you are within a degree, you are good (no need to re-time). *When you re-time, you will override (erase) the previous setting – information you need to capture and document if timing has, in fact, moved.*
- 3) **Thermal Sticker:** Ignitions come with a thermal sticker that will trip (turn from a light eggshell white color to gray or gray/black) as case temperatures exceed 200 degrees (F). Dark gray or solid black indicates a period of significant over-temp. If tripped, review blast cooling and/or other cooling impediments.
- 4) **Plug Leads:** (500 hr.) Ohm Check all plug wires and examine for evidence of wear or chafing. Lead resistance should be roughly 180 ohms per foot of wire for wire with no “F” markings. Newer wire sets will measure roughly 40 ohms per foot and will be marked “F40” at intervals along the wire.
- 5) **Spark Plugs:** Remove and inspect spark plugs for signs of unusual wear or build-up. Replace plugs at 125 hrs. Re-gap plugs per instructions. When re-installing auto style plugs with auto plug adapters, review plug/adapter installation guidelines. Ref. Appendix 1.
- 6) **Shaft Inspection:** *(500 hr. or annual inspection – see Note 1)* Remove ignition and examine (aggressively) the shaft for bearing play – *disassembly of ignition is not necessary.* Look for excessive radial and axial play. Shaft rotation should be free, with no catching, flat spots, or grinding. The seal at the base of the shaft is stiff, so considerable lateral force may be needed to detect rocking (bearing play) in the assembly behind the seal.
- 7) Reinstall the ignition - see Setup instructions.
- 8) Verify proper operation including:
 - a. Ramp Check.
 - b. Cut-Out test – record results in logbook for L, R, Both

Note 1: Ignitions with A) serial number 8245 and after, or B) having a mechanical overhaul after August 2022, have an enhanced bearing stack. Shaft inspection requirement for these units is 500 hrs. We recommend others continue with annual shaft inspection.

Wiring Diagram

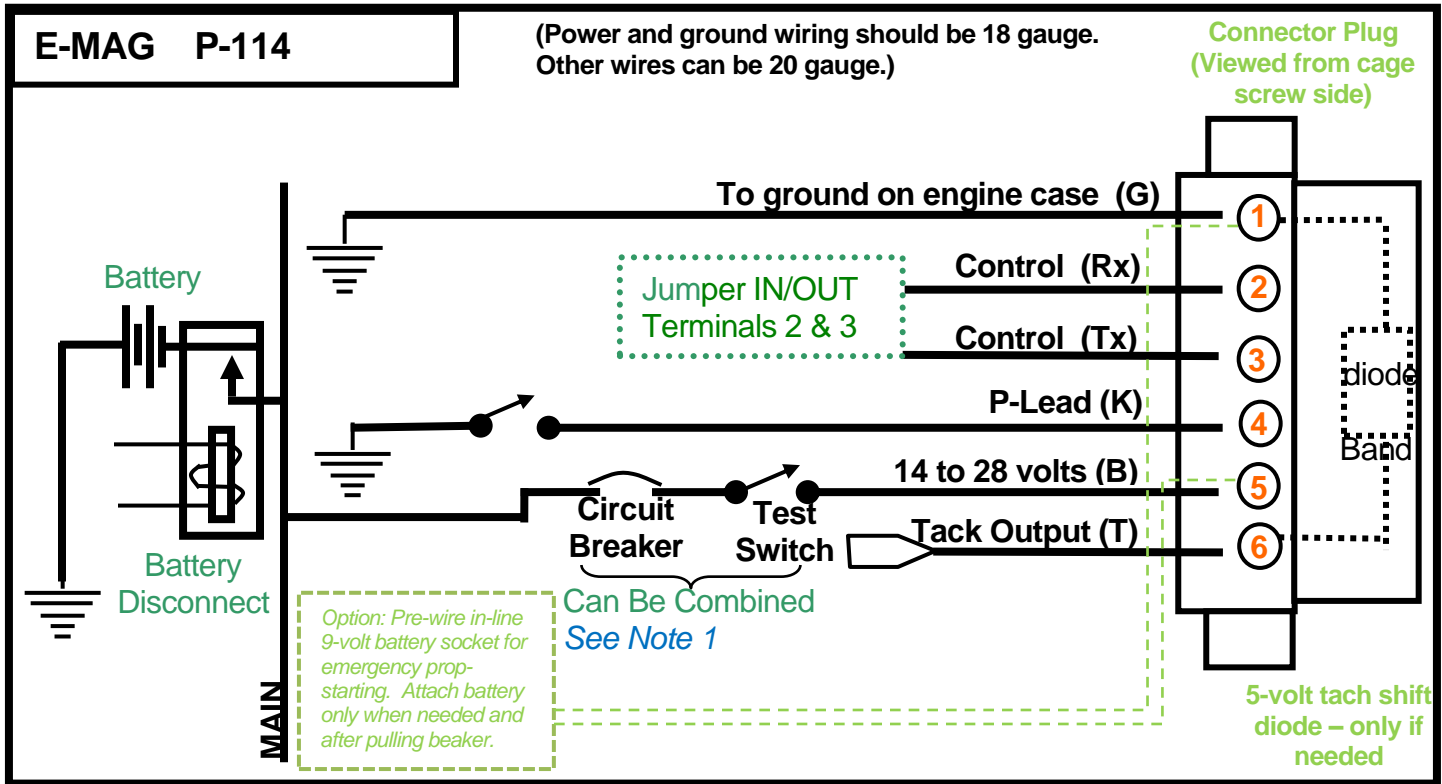

Note 1: The power test switch lets the operator turn aircraft power OFF for testing the ignition internal alternators – see Operating Notes and Ignition Checks earlier in the manual. The power test switch can be configured several ways and is largely a matter of installer/operator preference.

- 1) If using switchable circuit breakers (vs. fuses) the breaker itself can be used as a power test switch - one breaker per ignition.
- 2) A dedicated power test switch can also be used. One such implementation to consider is a momentary push button switch (non-latching, normally closed – push to open, one switch per ignition) that offers the following advantages:
 - a) A push button is not likely to be mistaken, by sight or by feel, for other switches.
 - b) It cannot inadvertently be left in the OFF position.
 - c) It can be located close to kill switch for ergonomic one-handed operation.
 - d) Can pair with either key switch or toggle switches as shown below.



Placement suggestions for pushbutton power test switches with key or toggle p-lead switches

- Momentary pushbuttons.
- Normally closed - push to open.
- Non-latching.
- One per ignition.

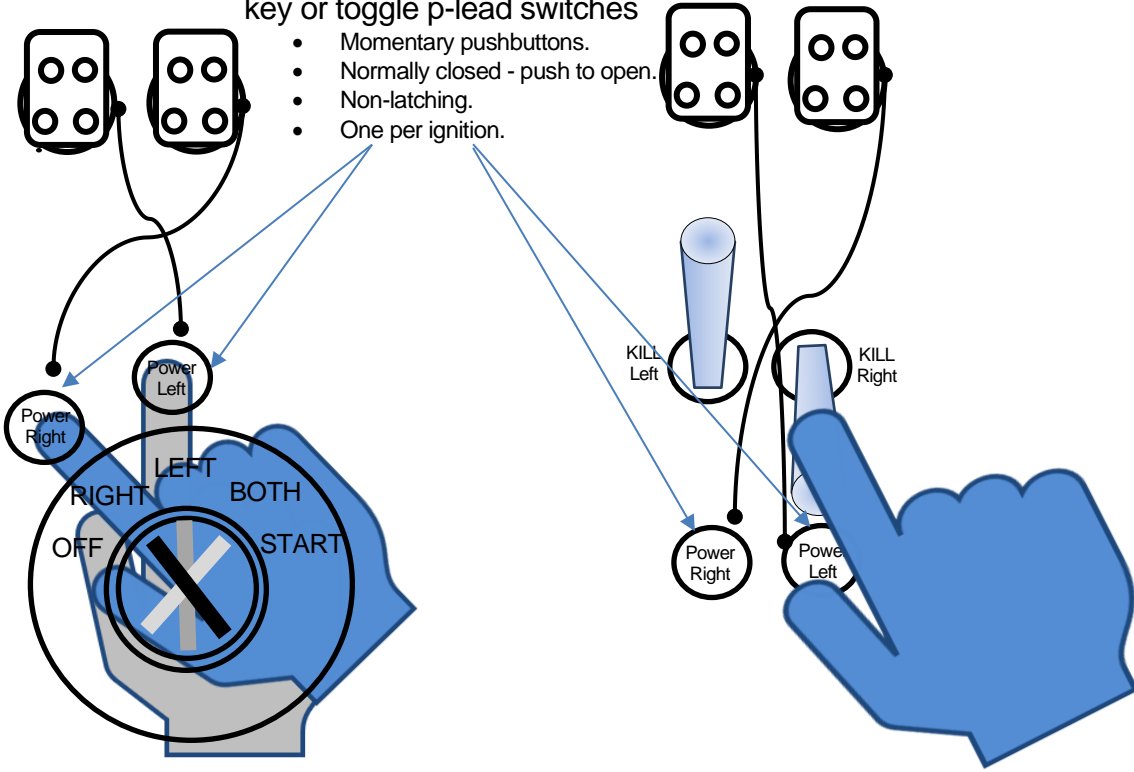

Appendix 1: Spark Plugs & Adapters

Short Reach Plugs (uses SR plug adapter)

- 1) NGK Spark Plug BR8ES 2.5mm center electrode. Stock #3961 has a solid terminal tip (preferred). Stock #5422 has a screw on tip – if used make sure the tip is well secured.
- 2) NGK Spark Plug BR8EIX iridium electrode with solid tip. Stock #6747 has a solid terminal tip (preferred)

Long Reach Plugs (uses LR or LRX adapters)

- 1) Denso Spark Plug IKH27 (stock #5347) has an iridium electrode with a solid terminal tip.

IMPORTANT: Remember to **FIRST** install spark plug in the adapter (fully seated and finger tight). **THEN**, insert the combined plug/adapter assembly in the engine and tighten to **18 ft/lb** (standard auto plug torque) through the spark plug **ONLY**. **Do NOT torque the adapter itself**. If you torque the adapters directly, stress will be focused underneath the adapter head and it can fail during installation. Such failures are not covered under warranty. Use anti-seize (sparingly) on the outer/engine side of adapters.

Operators need to monitor spark plug condition and adjust the plug temperature range if needed. The temperature rating is indicated by the NGK “8” or the Denso “27” reference in the plug number. If selecting a different range, remember that lower numbers indicate a hotter temperature rating, and higher numbers indicate a cooler rating.

Appendix 2 : Tach Specs

- 1) Bus power – Control Plug terminal #5 for 12, 24, or 48-volt systems
 - a) Minimum - 10 volts
 - b) Maximum - 58 volts
 - c) Current draw from bus:
 - i) less than 0.5 amp (normal operating conditions)
 - ii) less than 1.0 amp (maximum draw with no-op internal alternator)
- 2) Tach – Control Plug terminal #6
- 3) Ground – Control Plug terminal #1 is essential for bus power and tach signal circuits. You cannot rely on the ignition mount to provide stable ground.

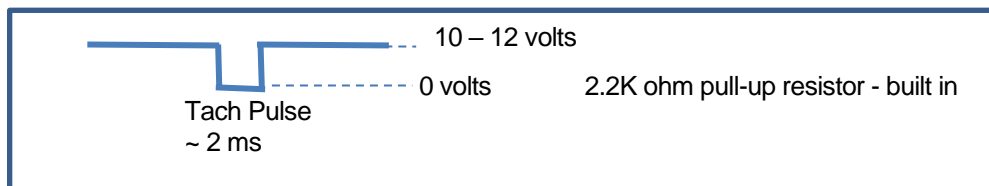

Appendix 3: Installation Checklist

Installing your E-MAG ignition will require:

- 1) Attaching three (four if you use the tach) wire connections from the ignition Control Plug.
- 2) Installing spark plugs and spark plug leads.
- 3) Installing a manifold pressure tube and a pulse dampener between the engine and ignitions.
- 4) Blast tube cooling.
- 5) Installing your E-MAG ignition on the engine.
- 6) Time the ignition to match your engine.
- 7) Test, tune, and monitor to ensure proper operation.

Order Items

P-114 L4 (Lycoming™) or P-144 C4 (Continental™) ignition set:

- 1) 1 ignition module
- 2) Incidentals Kit – comes with each ignition
 - a) 1 each - 6-pin Control Plug
 - b) 1 each - Ignition gasket
 - c) 36" silicone MAP tube (1/8"ID x 1/4" OD)
 - d) 2 each - Nylon ratchet clamps for MAP tubing
 - e) 1 each - Tach shift diode
 - f) 1 each – Blue pulse dampener – plastic double ended barb fitting

Optional Items – must specify when ordering

- 1) 2 each - Mounting Studs – 31C12 replaces longer impulse mag studs
- 2) [Lycoming] 1 each - non-impulse ignition drive gear
- 3) [Continental] 1 each - drive gear adapter kit
- 4) 1 each Mounting clamp kit – K3784 (contains 2 clamps)

Auto Plug Adapter sets of 4

- 1) 4 each - auto plug adapters - specify "LR" long-reach, "SR" short-reach
- 2) 4 each - copper gaskets

Harness (spark plug wires) sets of 4

- 1) 4 each – spark plug leads

Hardware and fittings NOT included

- 1) Fittings, and heat barrier tubing (if needed) to attach manifold pressure to your induction system
- 2) P-lead switch to control the ignition ON/OFF function (you can re-use an existing switch)
- 3) Fuse or breaker for bus protection and/or power test switch
- 4) Blast Tube cooling (new or re-use existing)
- 5) Spark Plugs – readily available at auto parts outlets
- 6) Spark plug wire supports and wire separators

Appendix 4 : Lead Fabrication

Standard lead sets are pre-terminated on both ends – no assembly required. However, if you want to customize, shorten or repair a lead, the following guide is taken from earlier trim-to-fit kits we used to offer.

Trim-To-Fit Harness

Lead kits use our custom low-noise, distributed inductance, plug wire that is not shielded. We have no (zero) reports of noise problems from customers using this wire when properly installed and in good condition. If you do hear spark noise, something is not installed or functioning properly. Plug “clicking” noise over the radio is a useful maintenance signal. Something is loose or worn and arcing - which causes radio clicking noise. Leads should be kept separated. Do NOT bundle them together which can cause them to be inductively coupled. Wire looms can be purchased at auto parts stores, but a simple separator can be fabricated out of tie-wraps and ¼” segments of leftover MAP sensor hose.



Criss-Cross vs. Up-Down

It's relatively immaterial whether you route plug leads in the traditional magneto criss-cross fashion (one ignition wired to alternating upper and lower plugs) or one ignition firing all the upper plugs and the other ignition firing all the lower plugs.

Organizing leads

Because plugs in each Bank fire simultaneously, the coil attachments, within each Bank, are interchangeable. Example: Plug wires for cylinders 1&2 can attach to either coil tower of Bank A. This flexibility can reduce congestion and wiring cross-over at the back of the ignition when attachments favor routing to the left and right sides of the engine.

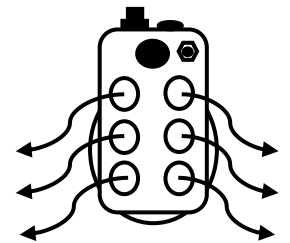

Lead Fabrication - Trimming

The red outer jacket and the white inner layers are separated by a reinforcing fiber weave. The conductive element is a spiral wound wire around a Kevlar core (avoid when trimming). Use a razor blade to trim the OUTERMOST red and fiber layers ONLY 3/4” from the end, all the way around the wire. Avoid cutting anywhere near the center core. The white insulation layer separates easily as you twist the trimmed outer jacket.

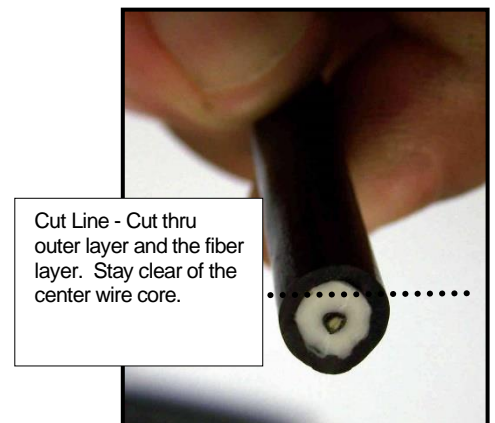

Note 1: The center core is easily nicked and weakened by contact with a Stripping tool or a blade. DO NOT use the wire stripping station on the crimp tool.



Terminals and Boots

Coil ends - The brass terminals and 90-degree flat-backed boots are for the coil end connections. Run the wire completely through the boot so you have a couple of inches extended past the boot. This will give you room to work the wire and terminal. A light coating of **SILICONE SPRAY** (not included) is required to lubricate the wire as you work it through the boot.

Plug ends – *90-degree boots and terminals are standard, but you can specify straight plug boots and terminals (when placing your order) at no additional cost.* With either style, you can crimp the terminal to the wire and then insert the assembly into the boot with silicone spray lubrication.

Note 1: It is best to push wire into the boot (rather than pulling) to avoid straining the wire core.

Note 2: Free the terminals from their strips with wire cutters. The terminals are NOT finger friendly. They will easily cut if not handled carefully.

Pre-Crimp - Fold the $\frac{3}{4}$ "

of exposed wire core back against the lead and position it in the crook between the terminal ears. Then finger pinch the terminal ears to 1) provide a preliminary snug fit, and 2) reduce the spread between the ears so they fit in the "W Crimp"

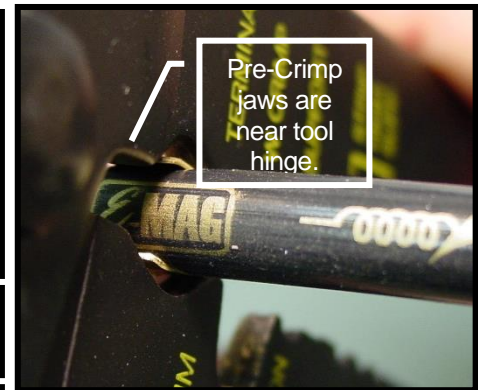
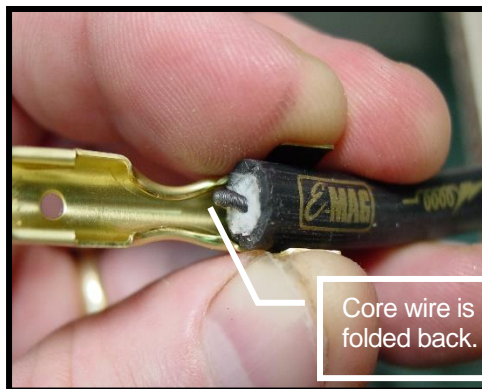

station of the crimping tool. Position so you have at least $\frac{1}{8}$ " of plug wire past the terminal ears.

Final Crimp - Crimp the terminal using the W Crimp Station on the Tool. Position the ears so they feed toward the side with the "W" point. The ears will roll back toward each other and imbed themselves in the outer jacket as the Final Crimp is formed. Push (not pull) the terminal to final position inside the boot.

Coil terminals will need to be bent 90 degrees (at the narrow section) before positioning in the boot.

Resistance Check - Verify the finished leads are assembled correctly with a simple ohm check. Each lead should produce roughly 180 ohms of resistance per foot of plug wire. To check, disconnect the leads at both ends so you can make (firm) ohmmeter contact with the terminals on each end. Watch the ohmmeter display while you exercise each end vigorously (twist/bend/tug) to

see if the reading jumps significantly (several times the normal range). To repair a crimped terminal end, simply snip off the bad end (assuming you have an inch or so to spare) and replace with a new terminal.

Note 1: Resistance checks are also recommended at annual inspection. It tests the condition of the conductive components, but it does not check the electrical insulation, which is another way that wires can fail. A visual inspection of plug wire is recommended, especially in areas of possible chafing.

Harness Terminations

The terminals on both ends of the plug wire are secured by a spring steel outer band with a detent. Verify that you feel and/or hear the steel band detent **snap-lock** as the terminal slips over the connecting post:

- 1) **Coil Terminals** - The coil terminal post inside the tower has 3 grooves. As you push the circular terminal onto the post, you will feel and/or hear a series of sharp clicks as the terminal detent snaps over these grooves.
- 2) **Plug Terminals:** Spark plugs have an hourglass shaped cap. You will feel and/or hear a sharp click as the terminal snaps over the plug cap.

In either case, **if you don't feel and/or hear the terminal snap**, remove and inspect for irregularities or damage. If needed, replacement terminals can be provided by E-MAG. **If not properly secured the leads can come lose, which risks interrupting ignition operation, and can damage the ignition coil. NEVER operate the ignition (fire plugs) without ALL high voltage loops (coil to wires to plugs to engine to plug to wire to coil) secured in place.**

Note 1: After plug wires are connected, verify the boot sleeve is fully inserted over the spark plug and coil towers and is relaxed, i.e. not "compressed" such that it's left pushing the boot away from the terminal.

Note 2: When removing the wires from either end, pull the boot/terminal straight off the post. If you use the 90-degree boot to lever/pry/bend the terminal off the post, you can distort and weaken the terminal spring retention clip.

Note 3: If using strap (Adel) clamps to secure plug leads, make sure the clamps are properly sized. Clamps for smaller size (previous) wire may be too tight and can crush/compromise the internal silicone insulation of our 8mm wire.

Appendix 6: Com port

We recommend using the built-in manual Timing Tools for initial setup and timing adjustments. That said, Series 113 and 114 ignitions have a built-in serial com port (via terminals #2 and #3) that allow electronic access to external devices that can monitor, display, and store various internal ignition settings. Com port can access the following configuration settings:

Advance Shift – moves the entire firing table (above low idle) up or down in increments of 1.4-degrees. Com connections on control plug terminals #2 and #3 will preempt the manual Jumper IN selection. However, Jumper IN equivalence can be accomplished by storing “0” in the Advance Shift setting.

Max Advance – sets a firing advance override that caps the instruction from the stored variable firing table. This tool is seldom needed in the four-cylinder fleet. Factory default Max Advance is around 42 degrees.

Max RPM – is an overspeed safety defense. If the engine were to suddenly unload (example - prop detach) the engine could rapidly overspeed to the point of destruction. Default Max RPM is roughly 3200, at which point the ignition will stop firing plugs. We recommend leaving it at this setting.

Tach PPR – The default tach pulse is (12-volt) 2 pulses per revolution. When necessary, the com port can change the signal to 1 pulse. **Pulse compatibility is easier to accomplish on the tach instrument end.**

Mode – a control that re-assigns the LED display function. Not used - leave in “Sense” mode.

Appendix 7: Left/Right Testing

As a means of evaluating a trial advance setting you can leave one ignition at a reference baseline and move the other ignition to a trial position (when operating E-MAGs on both sides). In your next run, switching between Left and Right ignitions will provide a back-to-back comparison. Once you identify your preferred setting, configure both ignitions to match. We suggest trials with small incremental changes of 1 to 2-degrees. In-flight Left/Right trials should only be made at safe altitudes. Trials at Ramp Check speeds are not a reliable indicator of in-flight behavior.

Lowering ignition timing slightly (less advance) to achieve your target CHT is a conservative timing adjustment. Increasing ignition timing (more advance) should be done cautiously - if at all. Overly aggressive timing can damage the engine. Operators need to be mindful of the limitations of CHT readings. Ignition timing is a significant, but not the only, factor influencing CHTs. Baffling, mixture, prop, cylinder design, cylinder break-in, air temperature, air density, humidity, fuel type, induction boost, and more can all affect the indicated CHT. Every installation should be considered unique – assume nothing.

Trial (Left/Right) Timing Comparisons

- 1) CHT reacts slowly but it's a primary indicator.
 - a) A rising CHT shift (across all cylinders) indicates an earlier firing ignition.
 - b) A falling CHT shift (across all cylinders) indicates a later firing ignition.
 - c) To lower CHTs, reduce the timing of the earlier firing ignition.
- 2) EGT responds almost instantaneously.
 - a) A rising EGT shift (across all cylinders) indicates a later firing ignition.
 - b) A falling EGT shift (across all cylinders) indicates an earlier firing ignition.
 - c) To lower CHTs, reduce the advance of the earlier firing ignition.
- 3) Test Left/Right ignition settings at high power (take-off) and low power (cruise) conditions:
 - 1) At high power (take-off and climb) settings (MAP at 25" or above) we don't expect to see significant temperature differences between magneto and E-MAGs. Plug firing angles should be very similar.
- 4) In cruise conditions (MAP 22" or lower) E-MAGs will have applied their full firing advance where CHTs are expected to rise slightly, and EGTs are expected to drop slightly (relative to cruise temps with magnetos).
- 5) Notable CHT/EGT shifts that appear in specific cylinders (a single cylinder, a pairing 1&2 or 3&4, or non-pairing 1&3 or 2&4) suggest other installation or operating issues - not ignition timing. see below.

Troubleshooting

After checking spark plugs, plug wires, control plug wiring, and you have completed the pull-thru test.

As a general guide only, ignition issues that cause:

- 1) **Temperature excursions in a single cylinder** only (temps in the paired cylinder are normal).
 - a) Observed while running on **both** Left and Right ignitions.
 - i) EGT rise and/or CHT fall in a single cylinder - can be caused by one of the plugs not

- firing. Note which cylinder rises, and go to b) below.
- ii) Running on both - EGT fall and/or CHT rise in a single cylinder (i.e. not the companion)– cannot be caused by ignition.
- b) Observed after switching to Left (alone) then Right (alone).
 - i) EGT and CHT fall, along with rough operation, is caused by a cylinder not firing. Note which ignition/cylinder and go to c) below.
 - c) **Remedy:** Single cylinder ignition issues can be caused by three items (only) – spark plug, plug wire, or coil. Finding and repairing the faulty part is straight forward and can be done on-site.
 - i) Pull spark plug from the affected cylinder to inspect for fouling. Replace with a new/clean spark plug. Test run engine. If the issue persists, proceed to ii).
 - ii) Detach plug wires at the coil for a) the affected cylinder and b) the paired cylinder. Cylinders 1&2 and 3&4 are pairs. Reattach plug wires using the other coil post (swap attachment points). Test run the engine.
 - (1) If the faulty cylinder moves to the other side, the problem is a bad coil.
 - (2) If the faulty cylinder stays on the same side, the problem is a bad plug wire.
 - (3) Replacement wires and coils can be obtained from E-MAG.
- 2) **Temperature excursions in paired cylinders (1&2 or 3&4)**
- a) Observe while running on **both** Left and Right ignitions.
 - i) Slight EGTs rise and slight CHTs drop on one cylinder pair. Note which pair has the temperature shift. Proceed to b).
 - b) Observe while briefly switching between Left (alone) then Right (alone).
 - i) EGTs and CHTs will crash, along with very rough engine on the faulty side.
 - c) On the faulty ignition, confirm the three wires at the green coil plug are secure. Give each wire a gentle tug with needle nose pliers next to the plug. Resecure any loose wires. If none are found return ignition to E-MAG for repair. Problem is not field serviceable.
- 3) **Temperature deviations for non-paired cylinders (1&3 or 2&4).**
- a) Observe while running on **both** Left and Right ignitions.
 - i) Repeat the pull-through test. Likely cause is incorrect plug wire to cylinder assignments that will be revealed by the pull-through test.
 - b) Observe while briefly switching between Left (alone) then Right (alone).
 - i) If plug wire assignments are incorrect on one side only, operation will be very rough on that side. Operation will normalize when running on the other ignition.
 - ii) If wire assignments are incorrect on both sides, operation will be barely possible.
- 4) **Temperature or operational issues affecting all cylinders.**
- a) Check ignition timing - TC Offset position and Jumper selection. Reevaluate timing selection.
 - b) May relate to fuel or mixture issues and not the ignition.
 - i) Pull spark plugs to inspect for black, carbon, wet/flooded indications.
 - c) Roughness occurring at low idle speeds but roughness clears at higher speeds may indicate bus power or ground connection issues.

Appendix 8: Drive Gears

Recover the drive gear from your existing non-impulse magneto:

[Lycoming™] Remove the cotter key, castle nut, and washers. A strap wrench is helpful while removing (or re-installing) the castle nut from the ignition shaft. A gear puller will be necessary to remove the gear without damaging the gear or the magneto. Install the drive gear on the E-MAG shaft using the woodruff key, washer(s), castle nut, and cotter pin provided. Two washers are included. Install washer with plastic center first and the thin washer second. Torque castle nut to low end of 120-150 in/lb range. Continue tightening nut until you have cotter pin alignment (not to exceed 150 in/lb). Insert, trim, and secure cotter pin ends as shown.



[Continental™] Remove drive gear from your magneto and reinstall on E-MAG. Position the drive gear, gear adapter, woodruff key, and the **thick washer provided with the gear adapter** on the ignition shaft as a loose stack. Tightening the castle nut will draw the adapter and gear onto the tapered shaft for a press fit. Insert, trim, and secure cotter pin ends as shown in [Lycoming™] photo above.

