



Product Documentation

Series 200-6XLF

Installation and Operating Guide

Instruction Set for Lycoming™ Styled
6 Cylinder Fixed Timing Ignition



200-6XLF V15
LYCOMING™ Style

Changes to Manual: Changes, corrections, and supplements may be made at any time (see version number on cover page – bottom right). Refer to E-MAG’s web page “Downloads” for the most recent version.

Alerts and Service Notes: Prior to installation and operation, review all applicable Alerts and Service Notes affecting your equipment. See E-MAG web site <https://emagair.com/service-notes/>.

Experimental Aircraft Only: Series 200-6XLF ignitions are not FAA certified and are not approved for installation on certificated aircraft. Use may be extended to ASTM applications if approved by the appropriate manufacturer.

Warranty: E-MAG electronic ignitions are warranted for one (1) year from the date of purchase. E-MAG will repair or replace ignition modules within the warranty period that, in E-MAG’s sole opinion, have not been subjected to abuse or attempted field repairs. This warranty is limited to the purchase price of E-MAG hardware and does not cover the engine or other engine components that may be affected by defects or failure of the system. Do not attempt to open or separate the ignition case sections. Doing so will void your ignition warranty.

CAUTION: The aircraft operator has the SOLE responsibility of determining how to appropriately and safely configure and control engine and ignition operation. Nothing stated by E-MAG in this manual, its employees, owners, agents, representatives, or affiliates should be construed as overriding or invalidating the engine manufacturer’s instructions. E-MAG has NOT performed testing on the wide variety of engines in popular use and cannot offer specific advice as to proper/suitable ignition configuration.

Notwithstanding engine manufacturer approval of certain engines to burn auto/alternative fuels, operators are SOLELY RESPONSIBLE for independently verifying proper engine behavior with standard and/or alternative fuels including the ignition setup AS CONFIGURED BY THE OPERATOR.

Markings:

- The letter “C” or “L” indicating a model compatible with most Continental™ or Lycoming™ style engines.
- Full model number ending with letter C or L indicating compatibility with most Continental™ or Lycoming™ style engines.
 - 200-6XC
 - 200-6XL
- Other part numbers may appear in the same area (disregard).

USING THIS MANUAL.....	3
SHORT-CUT	4
INSTALLATION AND OPERATION.....	5
COCKPIT CONTROLS.....	5
CONTROL PLUG WIRING.....	5
SETUP AND CONTROL SWITCHES.....	6
LED AND TONE SIGNALS.....	7
IGNITION ATTACHMENT.....	7
SPARK PLUG WIRING TO CYLINDERS	7
AUTO PLUGS AND ADAPTERS	8
SET IGNITION TIMING.....	9
BLAST TUBE COOLING	11
BUS CONDITION	11
PULL-THRU TEST	11
OPERATING NOTES	12
MAINTENANCE.....	13
WIRING DIAGRAM.....	14
APPENDIX 1 – SPARK PLUGS & ADAPTERS.....	16
APPENDIX 2 – ELECTRICAL SPECIFICATIONS	17

Using This Manual

This manual will include supplemental notes, comments, and tips that appear as *blue* text.

Different versions of this manual are available for Lycoming™ style and Continental™ style engines. Both versions can be downloaded from the E-MAG web site.

Lycoming™ is a registered trademark of Avco Corporation.
Continental™ is a registered trademark of Continental Aerospace Technologies™.

Exercise care when handling the ignitions, engine, or propeller. There is a significant risk of burn, electrical shock, injury, or even death. This manual may offer safety suggestions, but it is NOT to be considered a complete list of the potential hazards, NOR is it presented as a complete set of safety precautions that should be followed.

RISK OF EQUIPMENT DAMAGE: [*IMPORTANT***]** Firing the ignition without all high voltage loops in place, risks damaging the coils and/or electrical shock to the handler. If incurred, such damage may not be immediately evident. High voltage loops include the circuit from a given coil tower, to plug wire, to plug, to engine block, to companion plug, to companion plug wire, to companion coil tower. Each pair of cylinders (1&2, 3&4, 5&6) constitutes a separate high voltage loop.

ID	Date	Summary of Principal Changes
200-6XLF	4/06/23	Initial Product Release -
200-6XLF.v15	1/25/24	Added stocking part number to NGK spark plug BR8EIX Revised shaft inspection intervals to 500 hours.

Short-Cut

Ignition Timing:

Abbreviated overview for timing 200-6XLF ignition (*after all other installation and wiring instructions in the manual are complete*).

Colors/Tones: LED colors are green (background), yellow (TC reference), blue (Firing reference), and red (ALERT- ignition is hot/enabled). See Fig A.

- 1) Pre-position engine to flywheel Firing position (25-degrees or other as indicated on engine data plate). It does not matter if #1 or #2 is in compression – either one is fine. Verify bus power and kill switches (p-leads) are both OFF. Prior to insertion, connect the Control Plug to the ignition and turn bus power ON to the ignition. Rotate the ignition rotor drive to locate the blue LED (ignition Firing reference). Turn bus power OFF.
- 2) Maintain this (general) shaft position as you insert the ignition, with gasket. *See Note 1* Secure mounting clamps finger tight. Turn bus power ON. Slowly rotate ignition back and forth to reacquire the blue LED.. Then very slowly rotate ignition body CCW until the LED turns green. This CCW blue-to-green transition is the Firing setpoint. Tighten mounting clamps to 17 ft/lb.
- 3) Always confirm timing setpoints. Move engine between the TC flywheel setpoint (steady yellow with tone) and the Firing setpoint (steady blue) to verify both align with the appropriate flywheel marking – *see Note 2*.

Note 1: If the blue LED ignition position conflicts with hardpoints or obstacles in the aft engine area, you can reposition the drive receiver (rubber cushion cup in the engine) by removing it and reinserting it at a more favorable angle.

Note 2: The Firing setpoint is the trailing edge of the blue LED range where it turns green.

*When **setting** ignition timing, you will be rotating the **ignition body CCW** (viewed looking at the back of the installed ignition).*

*When **checking** ignition timing, you will be rotating the **engine (prop) CW** in the normal direction of rotation (viewed from the accessory case end of the engine to the prop on the far side).*

Note 3 Tones are fixed navigation aids to help locate the ignition TC and 25-degree positions. The precise timing target is the trailing edge LED blue to green transition, and not the tone.

Installation and Operation

Cockpit Controls

- 1) Circuit breaker or fuse (one per ignition).
- 2) Ignition kill switch (p-lead) - can be either:
 - a) Rotary switch OFF/R/L/Both/Start.
 - b) Toggle switch UP/ON and DOWN/OFF.
- 3) Ignition power test switch (*See Note 1*) is for testing ignition internal alternator – *see Ignition Checks*:
 - a) Ramp Checks - a basic ignition alternator check.
 - b) Cut-Out test – a stress test for ignition alternator and the overall system to determine the low-speed operating boundary. Should be done after installation, annual check, and after major maintenance.

Note 1: The E-MAG power test switch can be arranged several ways and is largely a matter of builder preference. That said, the two controls involved (kill switch and power test switch) can be located next to each other on the panel, making these tests one-handed, intuitive, and more ergonomic. Two examples are shown below the Wiring Diagram at the end of this manual.

Control Plug Wiring

- 1) Plug styles:
 - a) **Standard** circular Mil plug connector (PT06A-10-6S-SR or equivalent). This is a solder connection style plug with built-in strain relief clamp for attaching (20 and 22 AWG) control wires. Standard plug is roughly ½” longer than the optional potted plug (below), a better option if clearance is tight.
 - b) **Optional** circular plug connector with pig tail – circular connector (PT06P-10-6S or equivalent) with 96” of color-coded wire soldered and potted – see color references below and wiring schematic at the end of the manual.
- 2) Pinouts:
 - a) **Pin “A”** on circular plug (**Pig-Tail red wire**) - connects to your 14, 28, or 48-VDC aircraft bus – 20 AWG. (*See Note 8*) Route through a power test switch and suitable circuit protection. Possibilities are:
 - i) A 3 to 5-amp fuse and separate power test switch.
 - ii) A 3 to 5-amp switchable circuit breaker, which can satisfy circuit protection and power test function.
 - b) **Pin “B”** (**Pig-Tail black wire**) - connects to the cockpit panel ground – 20 AWG.
 - c) **Pins “C” and “D”** (**Pig-Tail not used**).
 - d) **Pin “E”** (**Pig-Tail yellow wire**) - connects to your cockpit kill switch (p-lead ignition ON/OFF). To turn ignition OFF, ground the p-lead with the switch. To turn ignition ON, un-ground the p-lead Switch - 22 AWG.

- e) **Pin “F” (Pig-Tail blue wire)** – connects to tach instrument (3 pulses per engine revolution) 22 AWG. (See Appendix 2)

Note 1: **[CAUTION]** Shower or vibrator type starting aids are **not compatible** and may damage your E-MAG – remove before installation.

Note 2: E-MAG p-lead wire does not make radio noise and does not require shielding. If replacing a magneto, your existing shielded p-lead wire can be re-used. If doing so, the outer shield needs to be trimmed clean and kept well clear of all end terminations.

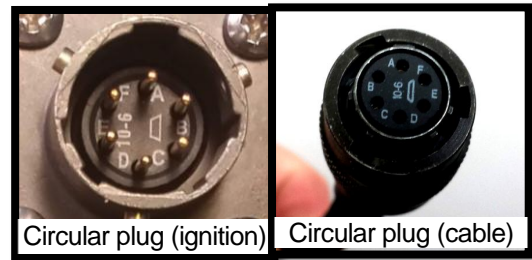

Note 3: All E-MAGs are “starting ignitions”. In a dual installation or if replacing a non-starting magneto, revise your starting procedures, and/or remove any key switch starting blocks (i.e., remove the jumper on the back of the key switch) to your E-MAGs.

Note 4: Whenever the aircraft bus is powered ON, the ignition is “awake”. It draws a small amount of current (approx. 40 milliamps) even when not firing plugs. Use the master bus switch (or breakers if necessary) to power down the ignitions when not in use.

Note 5: Do not power the ignition ON when you have a ground battery charger connected to the bus. Pulling the breaker will isolate the ignition while ground charging.

Note 6: Collect your tach signal from only one ignition unless your instrument has provisions for two (separate) tach inputs. Unlike a magneto, E-MAGs produce a tach signal even when kill switch is turned to OFF so there may be less need for tandem tach inputs.

Note 7: Tach signal is a 3 pulse/rev, low true, 33% duty cycle, 10 to 12-volt pulse - see Appendix 2. E-MAG’s tach output is a courtesy feature, unrelated to the ignition’s primary purpose. Due to the variety of instrument options available, our ability to support and troubleshoot interface issues is limited.

Note 8: Longer cable runs to a remote main battery (typical in RV10s, some canards, and others) may need to route ignition bus power thru a dedicated 16 AWG cable to the battery. This avoids sharing a long power cable with the starter motor, a combination that can exaggerate power dips and inhibit ignition operation while cranking. Low battery, cold temperatures, corroded terminations, etc. can have a similar affect.

Setup and Control Switches

- 1) **Configuration Button** (“Button”) is not used with this ignition version.
- 2) **Power Test Switch** - A cockpit bus power interrupt switch is used to test the ignition internal alternator. A switchable circuit breaker or separate test switch can perform this function.
- 3) **Kill Switch** (p-lead switch) - The traditional cockpit ignition ON/OFF (Left/Right) Kill Switch is

unchanged. The Kill Switch OFF position connects the E-MAG kill wire (p-lead) to ground. The ON position un-grounds the kill wire.

LED and Tone Signals

- 1) **RED LED indicates CAUTION.** When ignition is powered ON and kill switch is ON the LED will turn red and the unit is ready to fire plugs (“HOT”).
- 2) Other LED colors are enabled when the kill switch is OFF (ground p-lead).
 - a) Background color is green.
 - b) Setpoints:
 - i) Yellow* (with tone) signals ignition TC.
 - ii) Blue to green (trailing edge) signals the Firing setpoint.

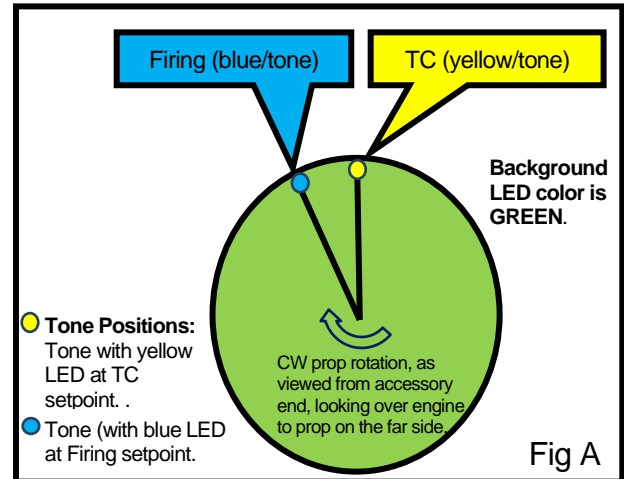

* *YELLOW is a composite color where two LED elements produce a dull and slight shimmering yellow effect (a limitation of the multi-color LED).*

Ignition Attachment

Verify the studs and clamps on hand are compatible with the E-MAG flange. E-MAG flange is 0.19” thick - not compatible with 0.31” clamps common to some magneto brands. Correct clamp thickness and reach are necessary for a proper fit. Remove magneto spacers (highlighted area in photo) and long studs. Long studs are identified by the roughly 1.75” of exposed stud. Replace with short studs (#31C12) that will have roughly .75” of exposed stud when installed. Ignitions will be secured by:

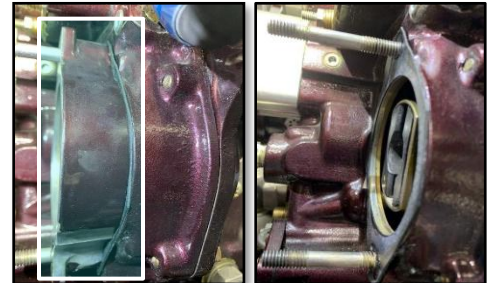

- 1) Two studs - one above and one below each ignition station.
- 2) Mounting clamps will fit over each stud and secure the ignition flange (with fiber gasket) to the case - see Setup below.

Tip: Penetrating oil and heating the engine case area around the studs with a heat-gun will make stud removal and replacement easier. (Remove rubber drive cushions before using heat gun.)

Spark Plug Wiring to Cylinders

As with any wasted-spark ignition, E-MAGs fire spark plugs in pairs. Cylinders 1&2, 3&4, 5&6 are pairs with plug leads connected to both ends of a double ended coil “Bank”.

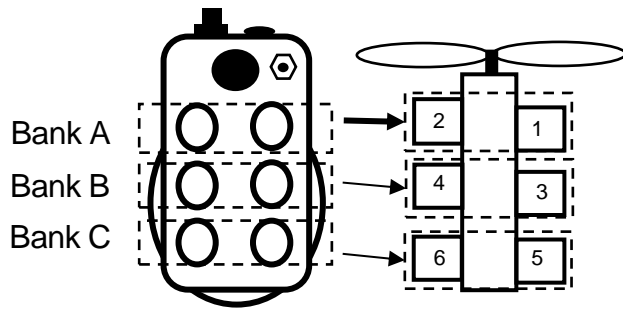

Lycoming™ styled engines:

- 1) Always - route Bank A to cylinders 1&2.
- 2) Most* will route Bank B to 3&4, Bank C to 5&6 as shown.

Always verify proper firing with the Pull-Thru test.

* CW rotating prop (as viewed from accessory end looking over engine to prop on far side).

*Note 1: The Pull-Thru test [highly recommended] is the best way to verify the installation follows correct bank (cylinder pair) firing order. This test uses encoder data at the lowest possible resolution, meaning **pull-thru firing positions cannot be used to check tracking accuracy**. During normal operation, dynamic quadrature counters are used to increase resolution and accuracy.*

Note 2: Ignition Bank firing sequence is A-B-C, regardless of the direction of the engine/ignition drive interface.

Note 3: If using strap (Adel) clamps to secure plug leads, make sure the clamps are properly sized. Reusing clamps for smaller size (previous 7mm aviation leads) wire may be too tight and crush/compromise the internal silicone insulation layer of our 8mm wire.

Auto Plugs and Adapters

Aircraft engines are tapped for 18mm spark plug threads. To use 14mm automotive style plugs, E-MAG can provide auto plug adapters. There are numerous auto spark plug styles and temperature ranges available through various outlets. E-MAG has NOT studied the relative durability or performance of different plug brands and styles. Customers need to monitor plug condition and evaluate and adjust as necessary. The plugs listed in Appendix A and have a history of good service. Set plug gaps at 0.030" to 0.035".

Long Reach (LR) vs. Short Reach (SR) Cylinders

Cylinders are made with two different spark plug thread depths. Match spark plugs and plug adapters (LR or SR) to your cylinder thread depth when ordering.

LR and SR cylinders can be identified by the aircraft spark plug call-out for your engine.

- 1) If it has the letter "M" - as in REMXXX, you will need SR plugs and adapters. If it has the letter "B" as in REBXXX, you will need LR plugs and adapters. The plug call-out can be:
 - a) Read directly from the side of your old aircraft style plugs.
 - b) Found on an aviation spark plug replacement chart.

Cylinder thread depth can also be measured directly:

- a) Short Reach ("SR") cylinders have plug thread depth of approx. 1/2".



SR LR LRX

b) Long Reach (“LR”) cylinders have plug thread depth of approx. 3/4”.

Spark Plugs - See Appendix 1 for specific spark plug recommendations.

IMPORTANT: Remember to **FIRST** install each spark plug in the adapter (fully seated and finger tight). **THEN**, insert the combined plug/adapter assembly in the engine and tighten to **18 ft/lb.** (standard auto plug torque) through the spark plug **ONLY**. **Do NOT torque the adapter itself.** If you torque the adapters directly, stress will be focused underneath the adapter head, and it can fail during installation. Such failures are not covered under warranty. Use anti-seize (sparingly) on the outer/engine side of adapters. Auto plug manufacturers do not recommend anti-seize on their plugs.

Set Ignition Timing

Colors/Tones: LED colors are green (background), yellow (TC reference), blue (Firing reference), and red (ALERT- ignition is hot/enabled). See Fig A.

- 1) Pre-position engine to flywheel Firing position (25-degrees or other as indicated on engine data plate). It does not matter if #1 or #2 is in compression – either one is fine. Verify bus power and kill switches (p-leads) are both OFF. Prior to insertion, connect the Control Plug to the ignition and turn bus power (**not** the kill switch) ON to the ignition. Rotate the ignition rotor drive to locate the blue LED (ignition Firing reference). Turn bus power OFF.
- 2) Maintain this (general) shaft position as you insert the ignition with gasket. *(See Note 1)* Secure mounting clamps finger tight. Turn bus power ON. Slowly rotate ignition back and forth to reacquire the blue LED. Then very slowly rotate ignition body CCW until the LED turns green. Tighten mounting clamps to 17 ft/lb.
- 3) **Always confirm timing setpoints.** Move engine between the TC flywheel setpoint (steady yellow with tone) and the Firing setpoint (steady blue) to verify both align with the appropriate flywheel markings see Note 2.

Note 1: If the blue LED position conflicts with hard points or obstacles in the aft engine area, you can reposition the drive receiver (rubber cushion cup in the engine) by removing it and reinserting at a more favorable angle.

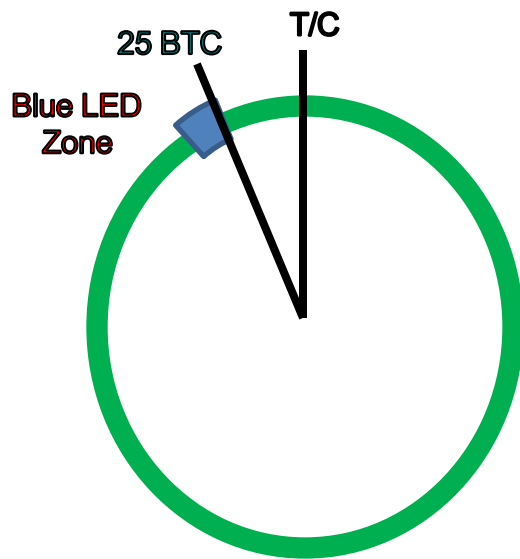

Find trailing edge LED blue-to-green:

When **setting** timing - rotate ignition body CCW.

When **checking** timing rotate engine (prop) CW - normal direction.

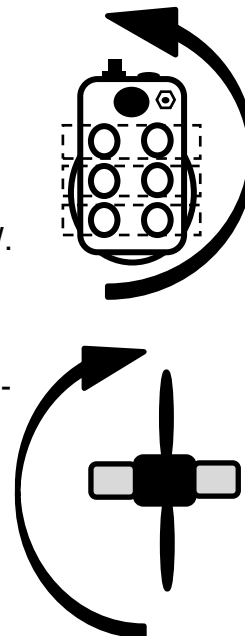

*Note 2: The Firing setpoint is the trailing edge of the blue LED where it turns green. When **setting** ignition timing, you will be rotating the **ignition body CCW** (viewed looking at the back of the installed ignition) with engine parked at the flywheel firing mark. When **checking** ignition timing, you will be rotating the **engine (prop) CW** in the normal direction of rotation (viewed from the accessory case end of the engine to the prop on the far side).*

*Note 3: **[Important]** Make sure Kill Switch (p-lead switch) stays OFF until all high-voltage connections (plugs, plug-wires, coil) are in place. Firing plugs without all high-voltage connections risks damaging the coil. A RED LED indicates ignition is ON/HOT (ready to fire plugs). No Setup procedure requires ignition to be HOT. If you see a steady RED LED – STOP, power OFF, and examine/correct kill switch (p-lead switch) setting or circuit.*

Note 4: Take care with the rubber drive socket cushions when removing or inserting the ignition. If they drop into the accessory case, retrieval can be problematic.

Note 5: There are two sets of flywheel marks. Markings on the prop side of the flywheel align with a pinhole reference in the starter motor case. Markings on the engine side of the flywheel align with the upper engine case seam.

Note 6: The internal permanent magnet alternator will impose an alternating magnetic push-pull force on the ignition shaft. When moving the engine by hand (i.e. positioning for timing) this magnetic ripple may produce a clicking sound in the accessory case if there is gear lash in the magneto accessory drive.

Blast Tube Cooling

E-MAGs are designed for a high-heat environment, but there are still thermal limitations and benefits to keeping the equipment as cool as possible. Blast tube cooling is a simple way to reduce operating temperatures, and we consider them mandatory. Blast tubes should be directed at the round neck, immediately behind the mounting flange.

The mere presence of blast-tubes does not guarantee they are operable and/or effective. Operators can verify the ignitions are operating within temperature guidelines (under 200F during flight). Thermal peaks typically occur on the ground after shutting down. A thermal reactive label is installed on the electronics case. It will remain white unless heated above 200F. Minor incursions over 200F (turning sticker light grey) are not significant. If it turns dark grey to solid black, temps may have reached 235F or more, indicating further investigation is warranted.

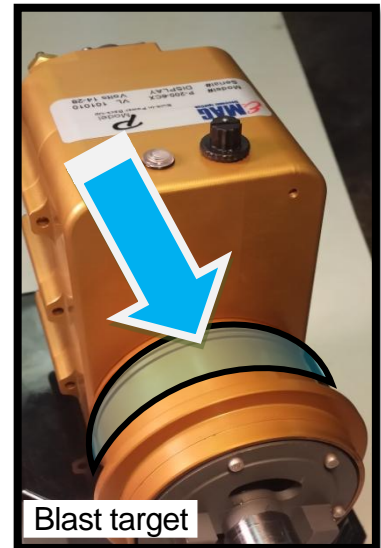

Bus Condition

E-MAG's have power dip protection to guard against severe voltage drops that occur when the starter motor is engaged. Low battery, long cable runs, undersized cable, corroded terminals, cold temperatures, etc.) can all aggravate the problem. The starter motor pulls the largest load on the electrical bus. Keeping non-essential loads OFF while cranking will help. *Note: We have no definitive guidance, but there are indications that light-weight lithium batteries may contribute to greater voltage swings during startup.*

Pull-Thru Test

The Pull-Thru test will confirm 1) plug wire assignments, 2) basic operation of firing circuits as follows:

1. Remove all spark plugs from the engine and reconnect them to the plug leads.
2. *IMPORTANT* Rest each plug on the engine case or convenient location such that the metal jacket of each plug is grounded to the engine block. *Alternatively, the plug metal jackets can be wired to the engine block, or plugs can be bundled directly to each other with metal jackets in direct contact of each other.*
3. One ignition at a time: Turn bus power ON, Kill Switch ON. LED will turn steady red. Rotate the prop by hand in the normal direction of travel and confirm all plug pairs fire in proper sequence. Any deviation indicates a wiring or setup error.
 - Both plugs for cylinders 1&2 (Bank A) fire at the starting lag position (roughly 4-degrees after TC).
 - Both plugs for Bank B fire 120 degrees later – see Note 3.
 - Both plugs for Bank C fire 240 degrees later – see Note 3.

Note 1: Plugs will not fire:

- 1) *When the engine is rotated the wrong direction.*
- 2) *Plugs fire only once per cycle. You cannot back up and fire them again. Keep pulling thru in the normal direction.*

Note 2: Multi-Strike. At pull-thru and cranking speeds, the ignition uses a (5) rapid strike sequence for each bank (helps with starting). This means the Pull-Thru Test will not produce the familiar single spark “click”. Instead, you’ll hear the plugs “buzz” - the sound of a multi-strike sequence.

Note 3: Pull-Thru firing positions cannot be used to verify ignition tracking accuracy. It only confirms proper wiring and circuit assignments.

Operating Notes

Starting:

- 1) **Flooding** can occur when excess fuel is introduced in the cylinders and is an issue for all types of ignitions. High energy spark is more resistant to flooding, but there are limits to how much can be tolerated.
- 2) **Wasted spark** ignitions fire spark plugs in pairs. On any given cycle only one cylinder, within the Bank pair, is in the compressed “firing” position. At that same point, the companion cylinder is between the intake and exhaust strokes (both valves are open). If sufficient fuel vapor is present in the companion cylinder (due to excess priming, throttle, mixture, or any other reason) the companion cylinder can ignite. This is called a “wasted side firing” and will send a pressure pulse down the intake and exhaust pipes. This event is easily mistaken as a backfire or a kick-back, which is different. Wasted side firing is remedied by adjusting the starting procedure to reduce excess fuel.

To reduce the risk of both (flooding and wasted side firing), **we recommend you begin your search for optimal start-up settings on the extreme lean side**, and gradually modify (richen) as necessary to achieve quick and consistent starts.

Lean-limit and mixture control: The familiar lean-rough boundary experienced with magnetos will shift (far leaner) or it may disappear entirely. The traditional (seat-of-the-pants) mixture control (lean to rough - then richen) may no longer apply. We suggest managing mixture by your temperature gauges.

Ignition Checks:

- 1) **Ramp Check** (roughly 1700 RPM):
 - a) Internal Alternator – The E-MAG internal alternator operates in parallel with power supplied by the aircraft bus. The ignition automatically transitions between aircraft power and internal alternator power as needed. Aircraft power is required for starting and sometimes for low idle speeds.
 - i) Your familiar Left/Right ignition check will be extended. After switching (kill switch) to one side and confirming smooth operation, you can then momentarily turn ignition power

test switch OFF and back ON after a couple of seconds. The engine should run smooth during this momentary bus power outage, which verifies the internal alternator is working.

ii) Repeat with the other ignition.

Any rough or degraded behavior (before, during, or after each side's Ramp Check) indicates a problem - not suitable for flight.

b) A little rehearsal will go a long way to making the Ramp Check (ignition power cycle) routine and automatic.

2) Minimum speed Cut-Out test

a) The minimum speed Cut-Out test should be done:

i) After initial installation.

ii) After major power plant maintenance.

iii) As part of your annual ignition inspection.

a) Operating on one ignition at a time (kill switch), lower engine speed to 1200 rpm. Then cut bus power to the operating ignition. A slight rpm dip can be expected due to reduced spark energy.

b) Very slowly, lower the engine rpm until the engine reaches idle stop or quits. A log-book entry can help track Cut-Out trends over time. Don't be surprised if you can't idle low enough to reach the low cut-out speed.

c) Repeat Cut-Out test on the other ignition and then with both ignitions.

Note 1: The cut-out test marks the low-speed and low-spark energy boundary of the entire system and not just the ignition. Spark energy is a significant, but not the only factor affecting cut-out speeds. Misadjusted idle mixture, partially fouled plugs, induction leaks, misadjusted prop, and other factors can adversely affect (elevate) cut-out speeds. E-MAG bench tests every ignition to verify they self-power, open air spark, down to 700 rpm prior to shipment. This is well below most in-flight idle speeds.

Note 2: When performing a cut-out test, when the engine falters allow it to come to a stop and fully power down.

Maintenance

Condition Inspection (annual unless otherwise noted)

- 1) Confirm ignition setpoints (TC, Firing) prior to removal. Look for deviation from prior settings. With properly working equipment, prior setpoints will not move (so long as ignition clamp position has not moved).
- 2) Check E-MAG web site for the most recent Manual (www.emagair.com/downloads) and Service Notes (www.emagair.com/service-notes) to verify equipment is current with all updates.
- 3) Ignitions come with a thermal sticker that will trip (turn from a light eggshell white color to gray or gray/black) as case temperatures exceed 200°F. Dark gray or solid black indicates a period of significant over-temp. If tripped, review blast cooling and/or other cooling impediments. Minor incursions over 200°F (light grey sticker) are not significant.

- 4) Ohm Check all plug wires and examine for evidence of wear or chafing. Lead resistance should be roughly 180 ohms per foot of wire for wire with no "F40" markings. Newer wire sets will measure roughly 40 ohms per foot and will have "F40" markings.
- 5) Remove and inspect spark plugs for signs of unusual wear or build-up. Replace plugs at 125 hrs. Re-gap plugs per instructions. When re-installing auto style plugs with auto plug adapters, review plug/adaptor installation guidelines.
- 6) Remove ignition and examine shaft for bearing play – *disassembly of ignition body is not necessary (or allowed)*. Look for excessive radial and axial play. Shaft rotation should be free, with no catching, flat spots, or grinding. While you have access, you can inspect the ignition drive cushions which may get hard over time. *Note: Shaft inspection is required every 500 hours.*
- 7) Reinstall the ignition - see Setup instructions.
- 8) Verify proper operation including:
 - a) Ramp Checks
 - b) Minimum speed Cut-Out test

Wiring Diagram

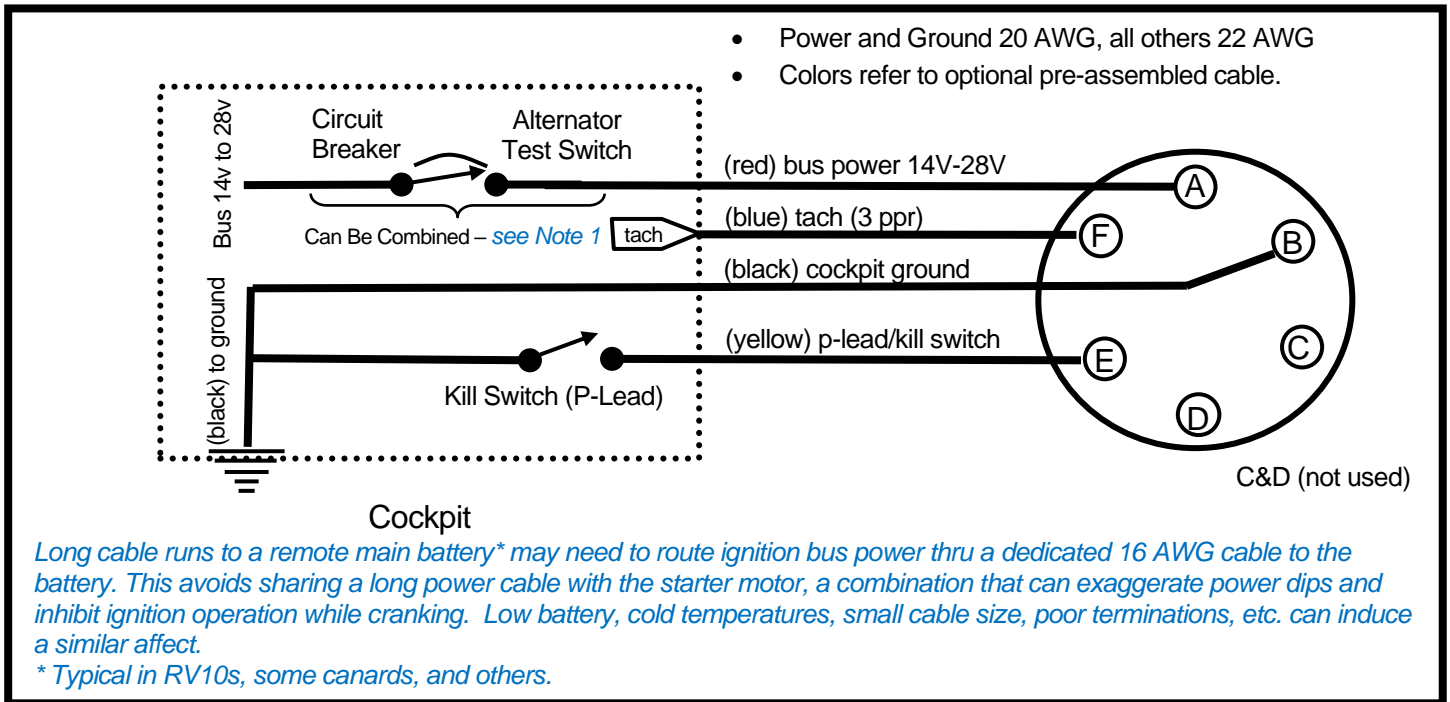

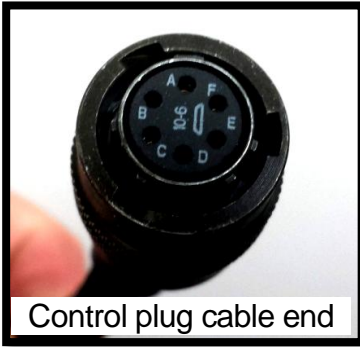

Control plug cable end



Optional potted pig-tail plug

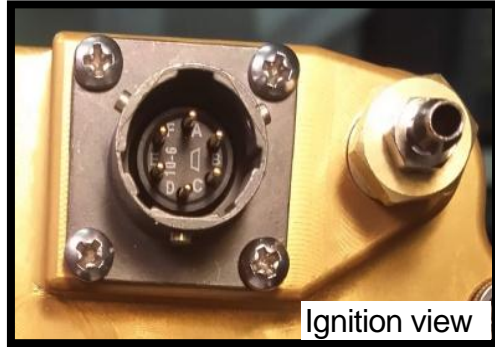

Ignition view



[left] Solder cup pins on back of standard control plug. Pin orientation matches the schematic above and is marked on the inner face of the plug itself. When assembling the Std. connector, remember to pre-position wires thru the strain clamp, plug shell, and shrink wrap before soldering.

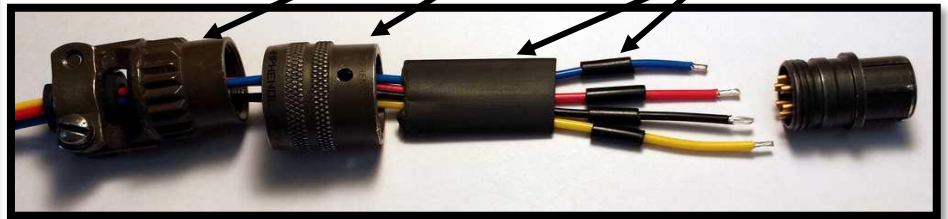

Note 1: The power test switch can be configured several ways and is largely a matter of installer/operator preference.

- 1) *If using switchable circuit breakers (vs. fuses) the breaker itself can serve as a power test switch - one breaker per ignition.*
- 2) *A dedicated power test switch has some advantages. One popular example is a momentary push button switch (non-latching, normally closed – push to open, one switch per ignition) **see image below.***
 - a) *A push button is less likely to be mistaken (by sight or by fee) for other nearby switches.*
 - b) *It cannot be inadvertently left in the OFF position.*
 - c) *It can be located next to the kill switch for ergonomic one-handed operation.*
 - d) *Can pair with either key or toggle kill switches, as shown below.*

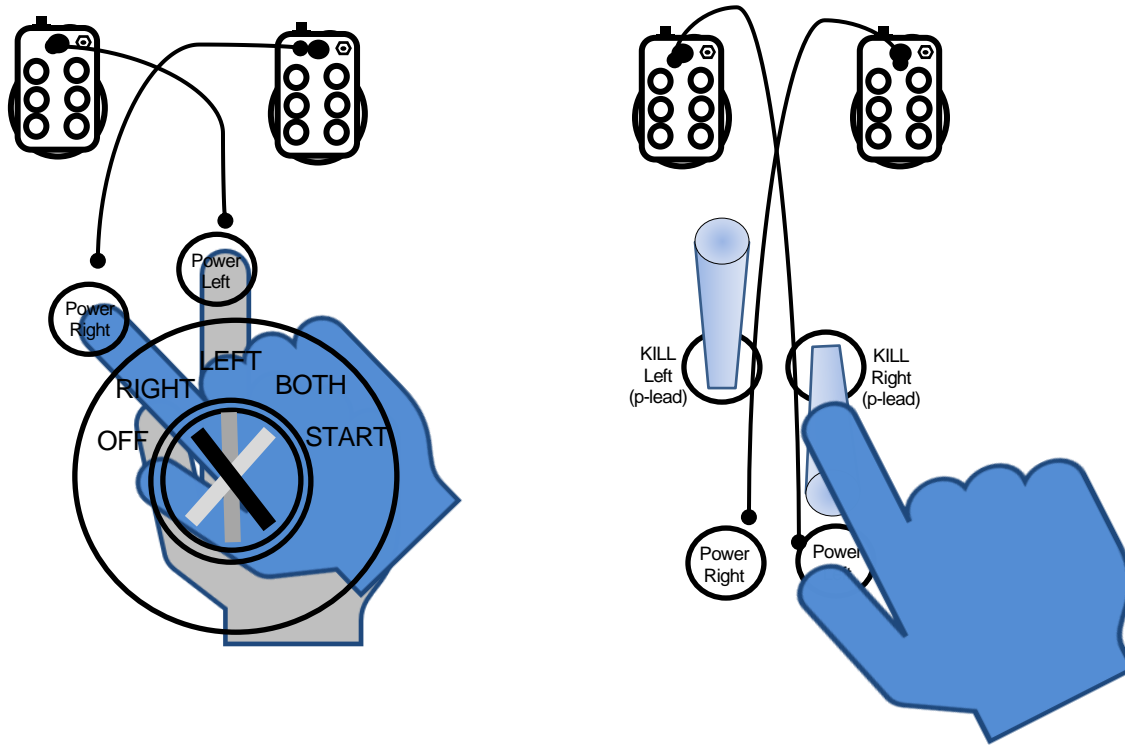

Appendix 1 – Spark Plugs & Adapters

Short Reach Plugs (uses SR plug adapter)

- 1) NGK Spark Plug BR8ES 2.5mm center electrode. Stock #3961 has a solid terminal tip (preferred). Stock #5422 has a screw on tip – if used make sure the tip is well secured.
- 2) NGK Spark Plug BR8EIX iridium electrode Stock #6747 has a solid terminal tip (preferred over screw-on tip style).

Long Reach Plugs (uses LR or LRX adapters)

- 1) Denso Spark Plug IKH27 (stock #5347) has an iridium electrode with a solid terminal tip.

IMPORTANT: Remember to **FIRST** install spark plug in the adapter (fully seated and finger tight). **THEN**, insert the combined plug/adapter assembly in the engine and tighten to **18 ft/lb** (standard auto plug torque) through the spark plug **ONLY**. **Do NOT torque the adapter itself**. If you torque the adapters directly, stress will be focused underneath the adapter head, and it can fail during installation. Such failures are not covered under warranty. Use anti-seize (sparingly) on the outer/engine side of adapters.

Operators need to monitor spark plug condition and adjust the plug temperature range as needed. The temperature rating is indicated by the NGK “8” or the Denso “27” reference in the plug number. If selecting a different range, remember that lower numbers indicate a hotter rating, and higher

numbers indicate a cooler rating. We suggest changing plug temps gradually (one temp increment at a time).

Appendix 2 – Electrical Specifications

- 1) Bus power – circular connector pin A (red) 12, 24, or 48-volts DC
 - a) Minimum - 10 volts
 - b) Maximum - 56 volts
 - c) Current draw from bus:
 - i) less than 0.5 amp (normal operating conditions at 12 volts)
 - ii) less than 1.0 amp (maximum draw with no-op internal alternator)
- 2) Tach – circular connector pin F (blue)

